

# ETAKE INVERTER

## GLORI SERIE

High Performance Sensorless Vector Control AC Drive



## User Manual

\* خلاصه دفترچه فارسی و انگلیسی \*



## Function Code Table

---

# Chapter 1 Function Code Table

If FP-00 is set to a non-zero number, parameter protection is enabled. You must enter the correct user password to enter the menu.

To cancel the password protection function, enter with password and set FP-00 to 0.

Group F and Group A are standard function parameters. Group U includes the monitoring function parameters.

The symbols in the function code table are described as follows:

"☆": The parameter can be modified when the AC drive is in either stop or running state.

"★": The parameter cannot be modified when the AC drive is in the running state.

"●": The parameter is the actually measured value and cannot be modified.

"\*": The parameter is factory parameter and can be set only by the manufacturer.

## 5.1 Standard Function Parameters

Function Code	Parameter Name	Setting Range	Default	Property
Group F0: Standard Function Parameters				
F0-00	G/P type display	1: G type (constant torque load) 2: P type (variable torque load e.g. fan and pump)	Model dependent	●
F0-01	Motor 1 control mode	0: Sensorless flux vector control (SFVC) 1: Closed-loop vector control (CLVC) 2: Voltage/Frequency (V/F) control	0	★
F0-02	Command source selection	0: Operation panel control (LED off) 1: Terminal control (LED on) 2: Communication control (LED blinking)	0	☆
F0-03	Main frequency source X selection	0: Digital setting (non-retentive at power failure) 1: Digital setting (retentive at power failure) 2: AI1 3: AI2 4: AI3	0	★

Function Code	Parameter Name	Setting Range	Default	Property
F0-03	Main frequency source X selection	5: Pulse setting (DI5) 6: Multi-reference 7: Simple PLC 8: PID 9: Communication setting	0	★
F0-04	Auxiliary frequency source Y selection	The same as F0-03 (Main frequency source X selection)	0	★
F0-05	Range of auxiliary frequency Y for X and Y operation	0: Relative to maximum frequency 1: Relative to main frequency X	0	☆
F0-06	Range of auxiliary frequency Y for X and Y operation	0%–150%	100%	☆
F0-07	Frequency source selection	Unit's digit (Frequency source selection) 0: Main frequency source X 1: X and Y operation (operation relationship determined by ten's digit) 2: Switchover between X and Y 3: Switchover between X and "X and Y operation" 4: Switchover between Y and "X and Y operation" Ten's digit (X and Y operation relationship) 0: X+Y 1: X-Y 2: Maximum 3: Minimum	00	☆
F0-08	Preset frequency	0.00 to maximum frequency (valid when frequency source is digital setting)	50.00 Hz	☆
F0-09	Rotation direction	0: Same direction 1: Reverse direction	0	☆
F0-10	Maximum frequency	50.00–320.00 Hz	50.00 Hz	★
F0-11	Source of frequency upper limit	0: Set by F0-12 1: AI1 2: AI2 3: AI3 4: Pulse setting (DI5) 5: Communication setting	0	★

Function Code	Parameter Name	Setting Range	Default	Property
F0-12	Frequency upper limit	Frequency lower limit (F0-14) to maximum frequency (F0-10)	50.00 Hz	☆
F0-13	Frequency upper limit offset	0.00 Hz to maximum frequency (F0-10)	0.00 Hz	☆
F0-14	Frequency lower limit	0.00 Hz to frequency upper limit (F0-12)	0.00 Hz	☆
F0-15	Carrier frequency	0.5–16.0 kHz	Model dependent	☆
F0-16	Carrier frequency adjustment with temperature	0: No 1: Yes	1	☆
F0-17	Acceleration time 1	0.00–650.00s (F0-19 = 2) 0.0–6500.0s (F0-19 = 1) 0–65000s (F0-19 = 0)	Model dependent	☆
F0-18	Deceleration time 1	0.00–650.00s (F0-19 = 2) 0.0–6500.0s (F0-19 = 1) 0–65000s (F0-19 = 0)	Model dependent	☆
F0-19	Acceleration/Deceleration time unit	0: 1s 1: 0.1s 2: 0.01s	1	★
F0-21	Frequency offset of auxiliary frequency source for X and Y operation	0.00 Hz to maximum frequency (F0-10)	0.00 Hz	☆
F0-22	Frequency reference resolution	1: 0.1 Hz 2: 0.01 Hz	2	★
F0-23	Retentive of digital setting frequency upon power failure	0: Not retentive 1: Retentive	2	☆
F0-24	Motor parameter group selection	0: Motor parameter group 1 1: Motor parameter group 2 2: Motor parameter group 3 3: Motor parameter group 4	0	★
F0-25	Acceleration/Deceleration time base frequency	0: Maximum frequency (F0-10) 1: Set frequency 2: 100 Hz	0	★
F0-26	Base frequency for UP/DOWN modification during running	0: Running frequency 1: Set frequency	0	★

Function Code	Parameter Name	Setting Range	Default	Property
F0-27	Binding command source to frequency source	Unit's digit (Binding operation panel command to frequency source)	000	☆
		0: No binding 1: Frequency source by digital setting 2: AI1 3: AI2 4: AI3 5: Pulse setting (DI5) 6: Multi-reference 7: Simple PLC 8: PID 9: Communication setting		
		Ten's digit (Binding terminal command to frequency source)		
		0–9, same as unit's digit		
		Hundred's digit (Binding communication command to frequency source)		
		0–9, same as unit's digit		
F0-28	Serial communication protocol	0: Modbus protocol 1: Profibus-DP bridge 2: CANopen bridge	0	☆
<b>Group F1: Motor 1 Parameters</b>				
F1-00	Motor type selection	0: Common asynchronous motor 1: Variable frequency asynchronous motor 2: Permanent magnetic synchronous motor	1	★
F1-01	Rated motor power	0.1–1000.0 kW	Model dependent	★
F1-02	Rated motor voltage	1–2000 V	Model dependent	★
F1-03	Rated motor current	0.01–655.35 A (AC drive power ≤ 55 kW) 0.1–6553.5 A (AC drive power > 55 kW)	Model dependent	★
F1-04	Rated motor frequency	0.01 Hz to maximum frequency	Model dependent	★
F1-05	Rated motor rotational speed	1–65535 RPM	Model dependent	★

Function Code	Parameter Name	Setting Range	Default	Property
F1-06	Stator resistance (asynchronous motor)	0.001–65.535 Ω (AC drive power ≤ 55 kW) 0.0001–6.5535 Ω (AC drive power > 55 kW)	Model dependent	★
F1-07	Rotor resistance (asynchronous motor)	0.001–65.535 Ω (AC drive power ≤ 55 kW) 0.0001–6.5535 Ω (AC drive power > 55 kW)	Model dependent	★
F1-08	Leakage inductive reactance (asynchronous motor)	0.01–655.35 mH (AC drive power ≤ 55 kW) 0.001–65.535 mH (AC drive power > 55 kW)	Model dependent	★
F1-09	Mutual inductive reactance (asynchronous motor)	0.1–6553.5 mH (AC drive power ≤ 55 kW) 0.01–655.35 mH (AC drive power > 55 kW)	Model dependent	★
F1-10	No-load current (asynchronous motor)	0.01 to F1-03 (AC drive power ≤ 55 kW) 0.1 to F1-03 (AC drive power > 55 kW)	Model dependent	★
F1-16	Stator resistance (synchronous motor)	0.001–65.535 Ω (AC drive power ≤ 55 kW) 0.0001–6.5535 Ω (AC drive power > 55 kW)	Model dependent	★
F1-17	Shaft D inductance (synchronous motor)	0.01–655.35 mH (AC drive power ≤ 55 kW) 0.001–65.535 mH (AC drive power > 55 kW)	Model dependent	★
F1-18	Shaft Q inductance (synchronous motor)	0.01–655.35 mH (AC drive power ≤ 55 kW) 0.001–65.535 mH (AC drive power > 55 kW)	Model dependent	★
F1-20	Back EMF (synchronous motor)	0.1–6553.5 V	Model dependent	★
F1-27	Encoder pulses per revolution	1–65535	1024	★
F1-28	Encoder type	0: ABZ incremental encoder 1: UVW incremental encoder 2: Resolver 3: SIN/COS encoder 4: Wire-saving UVW encoder	0	★
F1-30	A/B phase sequence of ABZ incremental encoder	0: Forward 1: Reserve	0	★

Function Code	Parameter Name	Setting Range	Default	Property
F1-31	Encoder installation angle	0.0°–359.9°	0.0°	★
F1-32	U, V, W phase sequence of UVW encoder	0: Forward 1: Reverse	0	★
F1-33	UVW encoder angle offset	0.0°–359.9°	0.0°	★
F1-34	Number of pole pairs of resolver	1–65535	1	★
F1-36	Encoder wire-break fault detection time	0.0s: No action 0.1–10.0s	0.0s	★
F1-37	Auto-tuning selection	0: No auto-tuning 1: Asynchronous motor static auto-tuning 2: Asynchronous motor complete auto-tuning 11: Synchronous motor with-load auto-tuning 12: Synchronous motor no-load auto-tuning	0	★
<b>Group F2: Vector Control Parameters</b>				
F2-00	Speed loop proportional gain 1	0–100	30	☆
F2-01	Speed loop integral time 1	0.01–10.00s	0.50s	☆
F2-02	Switchover frequency 1	0.00 to F2-05	5.00 Hz	☆
F2-03	Speed loop proportional gain 2	0–100	20	☆
F2-04	Speed loop integral time 2	0.01–10.00s	1.00s	☆
F2-05	Switchover frequency 2	F2-02 to maximum output frequency	10.00 Hz	☆
F2-06	Vector control slip gain	50%–200%	100%	☆
F2-07	Time constant of speed loop filter	0.000–0.100s	0.000s	☆
F2-08	Vector control over-excitation gain	0–200	64	☆
F2-09	Torque upper limit source in speed control mode	0: F2-10 1: AI1 2: AI2 3: AI3 4: Pulse setting (DI5) 5: Communication setting	0	☆
F2-10	Digital setting of torque upper limit in speed control mode	0.0%–200.0%	150.0%	☆



Function Code	Parameter Name	Setting Range	Default	Property
F2-13	Excitation adjustment proportional gain	0–20000	2000	☆
F2-14	Excitation adjustment integral gain	0–20000	1300	☆
F2-15	Torque adjustment proportional gain	0–20000	2000	☆
F2-16	Torque adjustment integral gain	0–20000	1300	☆
F2-17	Speed loop integral property	Unit's digit: integral separation 0: Disabled 1: Enabled	0	☆
F2-18	Field weakening mode of synchronous motor	0: No field weakening 1: Direct calculation 2: Automatic adjustment	1	☆
F2-19	Field weakening depth of synchronous motor	50%–500%	100%	☆
F2-20	Maximum field weakening current	1%–300%	50%	☆
F2-21	Field weakening automatic adjustment gain	10%–500%	100%	☆
F2-22	Field weakening integral multiple	2–10	2	☆
<b>Group F3: V/F Control Parameters</b>				
F3-00	V/F curve setting	0: Linear V/F 1: Multi-point V/F 2: Square V/F 3: 1.2-power V/F 4: 1.4-power V/F 6: 1.6-power V/F 8: 1.8-power V/F 9: Reserved 10: V/F complete separation 11: V/F half separation	0	★
F3-01	Torque boost	0.0% (fixed torque boost) 0.1%–30.0%	Model dependent	☆
F3-02	Cut-off frequency of torque boost	0.00 Hz to maximum output frequency	50.00 Hz	★
F3-03	Multi-point V/F frequency 1 (F1)	0.00 Hz to F3-05	0.00 Hz	★
F3-04	Multi-point V/F voltage 1 (V1)	0.0%–100.0%	0.0%	★

Function Code	Parameter Name	Setting Range	Default	Property
F3-05	Multi-point V/F frequency 2 (F2)	F3-03 to F3-07	0.00 Hz	★
F3-06	Multi-point V/F voltage 2 (V2)	0.0%–100.0%	0.0%	★
F3-07	Multi-point V/F frequency 3 (F3)	F3-05 to rated motor frequency (F1-04) Note: The rated frequencies of motors 2, 3, and 4 are respectively set in A2-04, A3-04, and A4-04.	0.00 Hz	★
F3-08	Multi-point V/F voltage 3 (V3)	0.0%–100.0%	0.0%	★
F3-09	V/F slip compensation gain	0%–200.0%	0.0%	☆
F3-10	V/F over-excitation gain	0–200	64	☆
F3-11	V/F oscillation suppression gain	0–100	Model dependent	☆
F3-13	Voltage source for V/F separation	0: Digital setting (F3-14) 1: AI1 2: AI2 3: AI3 4: Pulse setting (DI5) 5: Multi-reference 6: Simple PLC 7: PID 8: Communication setting 100.0% corresponds to the rated motor voltage (F1-02, A4-02, A5-02, A6-02).	0	☆
F3-14	Voltage digital setting for V/F separation	0 V to rated motor voltage	0 V	☆
F3-15	Voltage rise time of V/F separation	0.0–1000.0s It indicates the time for the voltage rising from 0 V to rated motor voltage.	0.0s	☆
F3-16	Voltage decline time of V/F separation	0.0–1000.0s It indicates the time for the voltage to decline from rated motor voltage to 0 V.	0.0s	☆
F3-17	Stop mode selection upon V/F separation	0: Frequency and voltage declining to 0 independently 1: Frequency declining after voltage declines to 0	0	☆

Function Code	Parameter Name	Setting Range	Default	Property
Group F4: Input Terminals				
F4-00	DI1 function selection	0: No function 1: Forward RUN (FWD) 2: Reverse RUN (REV) 3: Three-line control 4: Forward JOG (FJOG) 5: Reverse JOG (RJOG) 6: Terminal UP	1	★
F4-01	DI2 function selection	7: Terminal DOWN 8: Coast to stop 9: Fault reset (RESET) 10: RUN pause 11: Normally open (NO) input of external fault 12: Multi-reference terminal 1 13: Multi-reference terminal 2	4	★
F4-02	DI3 function selection	14: Multi-reference terminal 3 15: Multi-reference terminal 4 16: Terminal 1 for acceleration/ deceleration time selection 17: Terminal 2 for acceleration/ deceleration time selection	9	★
F4-03	DI4 function selection	18: Frequency source switchover 19: UP and DOWN setting clear (terminal, operation panel) 20: Command source switchover terminal 1 21: Acceleration/Deceleration prohibited 22: PID pause 23: PLC status reset 24: Swing pause 25: Counter input 26: Counter reset	12	★
F4-04	DI5 function selection	27: Length count input 28: Length reset 29: Torque control prohibited	13	★

Function Code	Parameter Name	Setting Range	Default	Property
F4-05	DI6 function selection	30: Pulse input (enabled only for DI5) 31: Reserved 32: Immediate DC braking 33: Normally closed (NC) input of external fault 34: Frequency modification forbidden 35: Reverse PID action direction	0	★
F4-06	DI7 function selection	36: External STOP terminal 1 37: Command source switchover terminal 2 38: PID integral pause 39: Switchover between main frequency source X and preset frequency	0	★
F4-07	DI8 function selection	40: Switchover between auxiliary frequency source Y and preset frequency 41: Motor selection terminal 1 42: Motor selection terminal 2 43: PID parameter switchover	0	★
F4-08	DI9 function selection	44: User-defined fault 1 45: User-defined fault 2 46: Speed control/Torque control switchover 47: Emergency stop	0	★
F4-09	DI10 function selection	48: External STOP terminal 2 49: Deceleration DC braking 50: Clear the current running time 51: Switchover between two-line mode and three-line mode 52-59: Reserved	0	★
F4-10	DI filter time	0.000-1.000s	0.010s	☆
F4-11	Terminal command mode	0: Two-line mode 1 1: Two-line mode 2 2: Three-line mode 1 3: Three-line mode 2	0	★
F4-12	Terminal UP/DOWN rate	0.01-65.535 Hz/s	1.00 Hz/s	☆
F4-13	AI curve 1 minimum input	0.00 V to F4-15	0.00 V	☆

Function Code	Parameter Name	Setting Range	Default	Property
F4-14	Corresponding setting of AI curve 1 minimum input	-100.00%~100.0%	0.0%	☆
F4-15	AI curve 1 maximum input	F4-13 to 10.00 V	10.00 V	☆
F4-16	Corresponding setting of AI curve 1 maximum input	-100.00%~100.0%	100.0%	☆
F4-17	AI1 filter time	0.00~10.00s	0.10s	☆
F4-18	AI curve 2 minimum input	0.00 V to F4-20	0.00 V	☆
F4-19	Corresponding setting of AI curve 2 minimum input	-100.00%~100.0%	0.0%	☆
F4-20	AI curve 2 maximum input	F4-18 to 10.00 V	10.00 V	☆
F4-21	Corresponding setting of AI curve 2 maximum input	-100.00%~100.0%	100.0%	☆
F4-22	AI2 filter time	0.00~10.00s	0.10s	☆
F4-23	AI curve 3 minimum input	0.00 V to F4-25	0.00 V	☆
F4-24	Corresponding setting of AI curve 3 minimum input	-100.00%~100.0%	0.0%	☆
F4-25	AI curve 3 maximum input	F4-23 to 10.00 V	10.00 V	☆
F4-26	Corresponding setting of AI curve 3 maximum input	-100.00%~100.0%	100.0%	☆
F4-27	AI3 filter time	0.00~10.00s	0.10s	☆
F4-28	Pulse minimum input	0.00 kHz to F4-30	0.00 kHz	☆
F4-29	Corresponding setting of pulse minimum input	-100.00%~100.0%	0.0%	☆
F4-30	Pulse maximum input	F4-28 to 50.00 kHz	50.00 kHz	☆
F4-31	Corresponding setting of pulse maximum input	-100.00%~100.0%	100.0%	☆
F4-32	Pulse filter time	0.00~10.00s	0.10s	☆

Function Code	Parameter Name	Setting Range	Default	Property
F4-33	AI curve selection	Unit's digit (AI1 curve selection)	321	☆
		Curve 1 (2 points, see F4-13 to F4-16)		
		Curve 2 (2 points, see F4-18 to F4-21)		
		Curve 3 (2 points, see F4-23 to F4-26)		
		Curve 4 (4 points, see A6-00 to A6-07)		
		Curve 5 (4 points, see A6-08 to A6-15)		
		Ten's digit (AI2 curve selection)		
		Curve 1 to curve 5 (same as AI1)		
		Hundred's digit (AI3 curve selection)		
Curve 1 to curve 5 (same as AI1)				
F4-34	Setting for AI less than minimum input	Unit's digit (Setting for AI1 less than minimum input)	000	☆
		0: Minimum value 1: 0.0%		
		Ten's digit (Setting for AI2 less than minimum input)		
		0, 1 (same as AI1)		
		Hundred's digit (Setting for AI3 less than minimum input)		
		0, 1 (same as AI1)		
F4-35	DI1 delay time	0.0–3600.0s	0.0s	★
F4-36	DI2 delay time	0.0–3600.0s	0.0s	★
F4-37	DI3 delay time	0.0–3600.0s	0.0s	★
F4-38	DI valid mode selection 1	Unit's digit (DI1 valid mode)	00000	★
		0: High level valid 1: Low level valid		
		Ten's digit (DI2 valid mode)		
		0, 1 (same as DI1)		
		Hundred's digit (DI3 valid mode)		
		0, 1 (same as DI1)		

Function Code	Parameter Name	Setting Range	Default	Property
F4-38	DI valid mode selection 1	Thousand's digit (DI4 valid mode)	00000	★
		0, 1 (same as DI1)		
		Ten thousand's digit (DI5 valid mode)		
		0, 1 (same as DI1)		
F4-39	DI valid mode selection 2	Unit's digit (DI6 valid mode)	00000	★
		0, 1 (same as DI1)		
		Ten's digit (DI7 valid mode)		
		0, 1 (same as DI1)		
		Hundred's digit (DI8 state)		
		0, 1 (same as DI1)		
		Thousand's digit (DI9 valid mode)		
		0, 1 (same as DI1)		
F4-40	AI2 input signal selection	0: Voltage signal	0	★
		1: Current signal		
Group F5: Output Terminals				
F5-00	FM terminal output mode	0: Pulse output (FMP) 1: Switch signal output (FMR)	0	☆
F5-01	FMR function (open-collector output terminal)	0: No output	2	☆
F5-02	Relay function (T/A-T/B-T/C)	1: AC drive running		
		2: Fault output (stop)		
		3: Frequency-level detection FDT1 output		
		4: Frequency reached		
		5: Zero-speed running (no output at stop)		
		6: Motor overload pre-warning		
		7: AC drive overload pre-warning		
		8: Set count value reached		
		9: Designated count value reached		
		10: Length reached		
		11: PLC cycle complete		
		12: Accumulative running time reached		
		13: Frequency limited		

Function Code	Parameter Name	Setting Range	Default	Property
F5-03	Extension card relay function (P/A-P/B-P/C)	14: Torque limited 15: Ready for RUN	0	☆
F5-04	O1 function selection (open-collector output terminal)	16: AI1 larger than AI2 17: Frequency upper limit reached		
F5-04	DO1 function selection (open-collector output terminal)	18: Frequency lower limit reached (no output at stop) 19: Undervoltage state output 20: Communication setting 21: Reserved 22: Reserved	1	☆
F5-05	Extension card DO2 function	23: Zero-speed running 2 (having output at stop) 24: Accumulative power-on time reached 25: Frequency level detection FDT2 output 26: Frequency 1 reached 27: Frequency 2 reached 28: Current 1 reached 29: Current 2 reached 30: Timing reached 31: AI1 input limit exceeded 32: Load becoming 0 33: Reverse running 34: Zero current state 35: Module temperature reached 36: Software current limit exceeded 37: Frequency lower limit reached (having output at stop) 38: Alarm output 39: Motor overheat warning 40: Current running time reached 41: Fault output (There is no output if it is the coast to stop fault and undervoltage occurs.)	4	☆



Function Code	Parameter Name	Setting Range	Default	Property
F5-06	FMP function selection	0: Running frequency	0	☆
F5-07	AO1 function selection	1: Set frequency	0	☆
F5-08	AO2 function selection	2: Output current	1	☆
		3: Output torque (absolute value)		
		4: Output power		
		5: Output voltage		
		6: Pulse input		
		7: AI1		
		8: AI2		
		9: AI3		
		10: Length		
		11: Count value		
		12: Communication setting		
		13: Motor rotational speed		
		14: Output current		
		15: Output voltage		
		16: Output torque (actual value)		
		F5-09		
F5-10	AO1 offset coefficient	-100.0%–100.0%	0.0%	☆
F5-11	AO1 gain	-10.00–10.00	1.00	☆
F5-12	AO2 offset coefficient	-100.0%–100.0%	0.00%	☆
F5-13	AO2 gain	-10.00–10.00	1.00	☆
F5-17	FMR output delay time	0.0–3600.0s	0.0s	☆
F5-18	Relay 1 output delay time	0.0–3600.0s	0.0s	☆
F5-19	Relay 2 output delay time	0.0–3600.0s	0.0s	☆
F5-20	DO1 output delay time	0.0–3600.0s	0.0s	☆
F5-21	DO2 output delay time	0.0–3600.0s	0.0s	☆

Function Code	Parameter Name	Setting Range	Default	Property
F5-22	DO valid mode selection	Unit's digit (FMR valid mode)	00000	☆
		0: Positive logic 1: Negative logic		
		Ten's digit (Relay 1 valid mode)		
		0, 1 (same as FMR)		
		Hundred's digit (Relay 2 valid mode)		
		0, 1 (same as FMR)		
		Thousand's digit (DO1 valid mode)		
		0, 1 (same as FMR)		
		Ten thousand's digit (DO2 valid mode)		
		0, 1 (same as FMR)		
F5-23	AO1 output signal selection	0: Voltage signal 1: Current signal	0	★
<b>Group F6: Start/Stop Control</b>				
F6-00	Start mode	0: Direct start 1: Rotational speed tracking restart 2: Pre-excited start (asynchronous motor)	0	☆
F6-01	Rotational speed tracking mode	0: From frequency at stop 1: From zero speed 2: From maximum frequency	0	★
F6-02	Rotational speed tracking speed	1–100	20	☆
F6-03	Startup frequency	0.00–10.00 Hz	0.00 Hz	☆
F6-04	Startup frequency holding time	0.0–100.0s	0.0s	★
F6-05	Startup DC braking current/ Pre-excited current	0%–100%	0%	★
F6-06	Startup DC braking time/ Pre-excited time	0.0–100.0s	0.0s	★
F6-07	Acceleration/Deceleration mode	0: Linear acceleration/ deceleration 1: S-curve acceleration/ deceleration A 2: S-curve acceleration/ deceleration B	0	★

Function Code	Parameter Name	Setting Range	Default	Property
F6-08	Time proportion of S-curve start segment	0.0% to (100.0% – F6-09)	30.0%	★
F6-09	Time proportion of S-curve end segment	0.0% to (100.0% – F6-08)	30.0%	★
F6-10	Stop mode	0: Decelerate to stop 1: Coast to stop	0	☆
F6-11	Initial frequency of stop DC braking	0.00 Hz to maximum frequency	0.00 Hz	☆
F6-12	Waiting time of stop DC braking	0.0–36.0s	0.0s	☆
F6-13	Stop DC braking current	0%–100%	0%	☆
F6-14	Stop DC braking time	0.0–36.0s	0.0s	☆
F6-15	Brake use ratio	0%–100%	100%	☆
<b>Group F7: Operation Panel and Display</b>				
F7-01	MF.K Key function selection	0: MF.K key disabled 1: Switchover between operation panel control and remote command control (terminal or communication) 2: Switchover between forward rotation and reverse rotation 3: Forward JOG 4: Reverse JOG	0	★
F7-02	STOP/RESET key function	0: STOP/RESET key enabled only in operation panel control 1: STOP/RESET key enabled in any operation mode	1	☆
F7-03	LED display running parameters 1	0000–FFFF Bit00: Running frequency 1 (Hz) Bit01: Set frequency (Hz) Bit02: Bus voltage (V) Bit03: Output voltage (V) Bit04: Output current (A) Bit05: Output power (kW) Bit06: Output torque (%) Bit07: DI input status	1F	☆

Function Code	Parameter Name	Setting Range	Default	Property
F7-03	LED display running parameters 1	Bit08: DO output status Bit09: AI1 voltage (V) Bit10: AI2 voltage (V) Bit11: AI3 voltage (V) Bit12: Count value Bit13: Length value Bit14: Load speed display Bit15: PID setting	1F	☆
F7-04	LED display running parameters 2	0000–FFFF Bit00: PID feedback Bit01: PLC stage Bit02: Pulse setting frequency (kHz) Bit03: Running frequency 2 (Hz) Bit04: Remaining running time Bit05: AI1 voltage before correction (V) Bit06: AI2 voltage before correction (V) Bit07: AI3 voltage before correction (V) Bit08: Linear speed Bit09: Current power-on time (Hour) Bit10: Current running time (Min) Bit11: Pulse setting frequency (Hz) Bit12: Communication setting value Bit13: Encoder feedback speed (Hz) Bit14: Main frequency X display (Hz) Bit15: Auxiliary frequency Y display (Hz)	0	☆

Function Code	Parameter Name	Setting Range	Default	Property
F7-05	LED display stop parameters	0000–FFFF Bit00: Set frequency (Hz) Bit01: Bus voltage (V) Bit02: DI input status Bit03: DO output status Bit04: AI1 voltage (V) Bit05: AI2 voltage (V) Bit06: AI3 voltage (V) Bit07: Count value Bit08: Length value Bit09: PLC stage Bit10: Load speed Bit11: PID setting Bit12: Pulse setting frequency (kHz)	33	☆
F7-06	Load speed display coefficient	0.0001–6.5000	1.0000	☆
F7-07	Heatsink temperature of inverter module	0.0–100.0°C	-	●
F7-08	Temporary software version	-	-	●
F7-09	Accumulative running time	0–65535 h	-	●
F7-10	Product number	-	-	●
F7-11	Software version	-	-	●
F7-12	Number of decimal places for load speed display	0: 0 decimal place 1: 1 decimal place 2: 2 decimal places 3: 3 decimal places	1	☆
F7-13	Accumulative power-on time	0–65535 h	0 h	●
F7-14	Accumulative power consumption	0–65535 kWh	-	●
<b>Group F8: Auxiliary Functions</b>				
F8-00	JOG running frequency	0.00 Hz to maximum frequency	2.00 Hz	☆
F8-01	JOG acceleration time	0.0–6500.0s	20.0s	☆
F8-02	JOG deceleration time	0.0–6500.0s	20.0s	☆
F8-03	Acceleration time 2	0.0–6500.0s	Model dependent	☆
F8-04	Deceleration time 2	0.0–6500.0s	Model dependent	☆

Function Code	Parameter Name	Setting Range	Default	Property
F8-05	Acceleration time 3	0.0–6500.0s	Model dependent	☆
F8-06	Deceleration time 3	0.0–6500.0s	Model dependent	☆
F8-07	Acceleration time 4	0.0–500.0s	Model dependent	☆
F8-08	Deceleration time 4	0.0–6500.0s	Model dependent	☆
F8-09	Jump frequency 1	0.00 Hz to maximum frequency	0.00 Hz	☆
F8-10	Jump frequency 2	0.00 Hz to maximum frequency	0.00 Hz	☆
F8-11	Frequency jump amplitude	0.00 Hz to maximum frequency	0.00 Hz	☆
F8-12	Forward/Reverse rotation dead-zone time	0.0–3000.0s	0.0s	☆
F8-13	Reverse control	0: Enabled 1: Disabled	0	☆
F8-14	Running mode when set frequency lower than frequency lower limit	0: Run at frequency lower limit 1: Stop 2: Run at zero speed	0	☆
F8-15	Droop control	0.00–10.00 Hz	0.00 Hz	☆
F8-16	Accumulative power-on time threshold	0–65000 h	0 h	☆
F8-17	Accumulative running time threshold	0–65000 h	0 h	☆
F8-18	Startup protection	0: No 1: Yes	0	☆
F8-19	Frequency detection value (FDT1)	0.00 Hz to maximum frequency	50.00 Hz	☆
F8-20	Frequency detection hysteresis (FDT hysteresis 1)	0.0%–100.0% (FDT1 level)	5.0%	☆
F8-21	Detection range of frequency reached	0.00–100% (maximum frequency)	0.0%	☆
F8-22	Jump frequency during acceleration/deceleration	0: Disabled 1: Enabled	0	☆
F8-25	Frequency switchover point between acceleration time 1 and acceleration time 2	0.00 Hz to maximum frequency	0.00 Hz	☆
F8-26	Frequency switchover point between deceleration time 1 and deceleration time 2	0.00 to maximum frequency	0.00 Hz	☆
F8-27	Terminal JOG preferred	0: Disabled 1: Enabled	0	☆

Function Code	Parameter Name	Setting Range	Default	Property
F8-28	Frequency detection value (FDT2)	0.00 to maximum frequency	50.00 Hz	☆
F8-29	Frequency detection hysteresis (FDT hysteresis 2)	0.0%–100.0% (FDT2 level)	5.0%	☆
F8-30	Any frequency reaching detection value 1	0.00 Hz to maximum frequency	50.00 Hz	☆
F8-31	Any frequency reaching detection amplitude 1	0.0%–100.0% (maximum frequency)	0.0%	☆
F8-32	Any frequency reaching detection value 2	0.00 Hz to maximum frequency	50.00 Hz	☆
F8-33	Any frequency reaching detection amplitude 2	0.0%–100.0% (maximum frequency)	0.0%	☆
F8-34	Zero current detection level	0.0%–300.0% (rated motor current)	5.0%	☆
F8-35	Zero current detection delay time	0.00–600.00s	0.10s	☆
F8-36	Output overcurrent threshold	0.0 % (no detection) 0.1 %–300.0% (rated motor current)	200.0%	☆
F8-37	Output overcurrent detection delay time	0.00–600.00s	0.00s	☆
F8-38	Any current reaching 1	0.0%–300.0% (rated motor current)	100.0%	☆
F8-39	Any current reaching 1 amplitude	0.0%–300.0% (rated motor current)	0.0%	☆
F8-40	Any current reaching 2	0.0%–300.0% (rated motor current)	100.0%	☆
F8-41	Any current reaching 2 amplitude	0.0%–300.0% (rated motor current)	0.0%	☆
F8-42	Timing function	0: Disabled 1: Enabled	0	☆
F8-43	Timing duration source	0: F8-44 1: AI1 2: AI2 3: AI3 (100% of analog input corresponds to the value of F8-44)	0	☆
F8-44	Timing duration	0.0–6500.0 min	0.0 min	☆
F8-45	AI1 input voltage lower limit	0.00 V to F8-46	3.10 V	☆
F8-46	AI1 input voltage upper limit	F8-45 to 10.00 V	6.80 V	☆

Function Code	Parameter Name	Setting Range	Default	Property
F8-47	Module temperature threshold	0–100°C	75°C	☆
F8-48	Cooling fan control	0: Fan working during running 1: Fan working continuously	0	☆
F8-49	Wakeup frequency	Dormant frequency (F8-51) to maximum frequency (F0-10)	0.00 Hz	☆
F8-50	Wakeup delay time	0.0–6500.0s	0.0s	☆
F8-51	Dormant frequency	0.00 Hz to wakeup frequency (F8-49)	0.00 Hz	☆
F8-52	Dormant delay time	0.0–6500.0s	0.0s	☆
F8-53	Current running time reached	0.0–6500.0 min	0.0 min	☆
F8-54	Output power correction coefficient	0.00%–200.0%	100.0%	☆
<b>Group F9: Fault and Protection</b>				
F9-00	Motor overload protection selection	0: Disabled 1: Enabled	1	☆
F9-01	Motor overload protection gain	0.20–10.00	1.00	☆
F9-02	Motor overload warning coefficient	50%–100%	80%	☆
F9-03	Overvoltage stall gain	0 (no stall overvoltage)–100	0	☆
F9-04	Overvoltage stall protective voltage	120%–150%	130%	☆
F9-05	Overcurrent stall gain	0–100	20	☆
F9-06	Overcurrent stall protective current	100%–200%	150%	☆
F9-07	Short-circuit to ground upon power-on	0: Disabled 1: Enabled	1	☆
F9-09	Fault auto reset times	0–20	0	☆
F9-10	DO action during fault auto reset	0: Not act 1: Act	0	☆
F9-11	Time interval of fault auto reset	0.1s–100.0s	1.0s	☆
F9-12	Input phase loss protection/ contactor energizing protection selection	Unit's digit: Input phase loss protection Ten's digit: Contactor energizing protection 0: Disabled 1: Enabled	11	☆



Function Code	Parameter Name	Setting Range	Default	Property
F9-13	Output phase loss protection selection	0: Disabled 1: Enabled	1	☆
F9-14	1st fault type	0: No fault 1: Reserved 2: Overcurrent during acceleration 3: Overcurrent during deceleration 4: Overcurrent at constant speed 5: Overvoltage during acceleration 6: Overvoltage during deceleration 7: Overvoltage at constant speed 8: Buffer resistance overload 9: Undervoltage 10: AC drive overload 11: Motor overload 12: Power input phase loss 13: Power output phase loss 14: Module overheat 15: External equipment fault 16: Communication fault 17: Contactor fault 18: Current detection fault 19: Motor auto-tuning fault 20: Encoder/PG card fault 21: EEPROM read-write fault 22: AC drive hardware fault 23: Short circuit to ground 24: Reserved 25: Reserved 26: Accumulative running time reached 27: User-defined fault 1 28: User-defined fault 2 29: Accumulative power-on time reached 30: Load becoming 0 31: PID feedback lost during running	-	●
F9-15	2nd fault type		-	●

Function Code	Parameter Name	Setting Range	Default	Property
F9-16	3rd (latest) fault type	40: With-wave current limit fault 41: Motor switchover fault during running 42: Too large speed deviation 43: Motor over-speed 45: Motor overheat 51: Initial position fault	-	●
F9-17	Frequency upon 3rd fault	-	-	●
F9-18	Current upon 3rd fault	-	-	●
F9-19	Bus voltage upon 3rd fault	-	-	●
F9-20	DI status upon 3rd fault	-	-	●
F9-21	Output terminal status upon 3rd fault	-	-	●
F9-22	AC drive status upon 3rd fault	-	-	●
F9-23	Power-on time upon 3rd fault	-	-	●
F9-24	Running time upon 3rd fault	-	-	●
F9-27	Frequency upon 2nd fault	-	-	●
F9-28	Current upon 2nd fault	-	-	●
F9-29	Bus voltage upon 2nd fault	-	-	●
F9-30	DI status upon 2nd fault	-	-	●
F9-31	Output terminal status upon 2nd fault	-	-	●
F9-32	Frequency upon 2nd fault	-	-	●
F9-33	Current upon 2nd fault	-	-	●
F9-34	Bus voltage upon 2nd fault	-	-	●
F9-37	DI status upon 1st fault	-	-	●
F9-38	Output terminal status upon 1st fault	-	-	●
F9-39	Frequency upon 1st fault	-	-	●
F9-40	Current upon 1st fault	-	-	●
F9-41	Bus voltage upon 3rd fault	-	-	●
F9-42	DI status upon 1st fault	-	-	●
F9-43	Output terminal status upon 1st fault	-	-	●
F9-44	Frequency upon 1st fault	-	-	●

Function Code	Parameter Name	Setting Range	Default	Property
F9-47	Fault protection action selection 1	Unit's digit (Motor overload, Err11)	00000	☆
		0: Coast to stop 1: Stop according to the stop mode 2: Continue to run		
		Ten's digit (Power input phase loss, Err12)		
		Same as unit's digit		
		Hundred's digit (Power output phase loss, Err13)		
		Same as unit's digit		
		Thousand's digit (External equipment fault, Err15)		
		Same as unit's digit		
		Ten thousand's digit (Communication fault, Err16)		
		Same as unit's digit		
		F9-48		
0: Coast to stop 1: Switch over to V/F control, stop according to the stop mode 2: Switch over to V/F control, continue to run				
Ten's digit (EEPROM read-write fault, Err21)				
0: Coast to stop 1: Stop according to the stop mode				
Hundred's digit: reserved				
F9-48	Fault protection action selection 2	Thousand's digit (Motor overheat, Err25)	00000	☆
		Same as unit's digit in F9-47		
		Ten thousand's digit (Accumulative running time reached)		
		Same as unit's digit in F9-47		

Function Code	Parameter Name	Setting Range	Default	Property
F9-49	Fault protection action selection 3	Unit's digit (User-defined fault 1, Err27)	00000	☆
		Same as unit's digit in F9-47		
		Ten's digit (User-defined fault 2, Err28)		
		Same as unit's digit in F9-47		
		Hundred's digit (Accumulative power-on time reached, Err29)		
		Same as unit's digit in F9-47		
		Thousand's digit (Load becoming 0, Err30)		
		0: Coast to stop 1: Stop according to the stop mode 2: Continue to run at 7% of rated motor frequency and resume to the set frequency if the load recovers		
		Ten thousand's digit (PID feedback lost during running, Err31)		
Same as unit's digit in F9-47				
F9-50	Fault protection action selection 4	Unit's digit (Too large speed deviation, Err42)	00000	☆
		Same as unit's digit in F9-47		
		Ten's digit (Motor over-speed, Err43)		
		Same as unit's digit in F9-47		
		Hundred's digit (Initial position fault, Err51)		
		Same as unit's digit in F9-47		
		Thousand's digit (Speed feedback fault, Err52)		
		Same as unit's digit in F9-47		
		Ten thousand's digit: Reserved		
F9-54	Frequency selection for continuing to run upon fault	0: Current running frequency	0	☆
		1: Set frequency		
		2: Frequency upper limit		
		3: Frequency lower limit		
		4: Backup frequency upon abnormality		

Function Code	Parameter Name	Setting Range	Default	Property
F9-55	Backup frequency upon abnormality	0.0%–100.0% (maximum frequency)	100.0%	☆
F9-56	Type of motor temperature sensor	0: No temperature sensor 1: PT100 2: PT1000	1	☆
F9-57	Motor overheat protection threshold	0–200°C	110°C	☆
F9-58	Motor overheat warning threshold	0–200°C	90°C	☆
F9-59	Action selection at instantaneous power failure	0: Invalid 1: Decelerate 2: Decelerate to stop	0	☆
F9-60	Action pause judging voltage at instantaneous power failure	80.0%–100.0%	90.0%	☆
F9-61	Voltage rally judging time at instantaneous power failure	0.00–100.00s	0.50s	☆
F9-62	Action judging voltage at instantaneous power failure	60.0%–100.0% (standard bus voltage)	80.0%	☆
F9-63	Protection upon load becoming 0	0: Disabled 1: Enabled	0	☆
F9-64	Detection level of load becoming 0	0.0%–100.0% (rated motor current)	10.0%	☆
F9-65	Detection time of load becoming 0	0.0–60.0s	1.0s	☆
F9-67	Over-speed detection value	0.0%–50.0% (maximum frequency)	20.0%	☆
F9-68	Over-speed detection time	0.0–60.0s	1.0s	☆
F9-69	Detection value of too large speed deviation	0.0%–50.0% (maximum frequency)	20.0%	☆
F9-70	Detection time of too large speed deviation	0.0–60.0s	5.0s	☆
<b>Group FA: Process Control PID Function</b>				
FA-00	PID setting source	0: FA-01 1: AI1 2: AI2 3: AI3 4: Pulse setting (DI5) 5: Communication setting 6: Multi-reference	0	☆
FA-01	PID digital setting	0.0%–100.0%	50.0%	☆

Function Code	Parameter Name	Setting Range	Default	Property
FA-02	PID feedback source	0: AI1 1: AI2 2: AI3 3: AI1 – AI2 4: Pulse setting (DI5) 5: Communication setting 6: AI1 + AI2 7: MAX ( AI1 ,  AI2 ) 8: MIN ( AI1 ,  AI2 )	0	☆
FA-03	PID action direction	0: Forward action 1: Reverse action	0	☆
FA-04	PID setting feedback range	0–65535	1000	☆
FA-05	Proportional gain Kp1	0.0–100.0	20.0	☆
FA-06	Integral time Ti1	0.01–10.00s	2.00s	☆
FA-07	Differential time Td1	0.00–10.000	0.000s	☆
FA-08	Cut-off frequency of PID reverse rotation	0.00 to maximum frequency	2.00 Hz	☆
FA-09	PID deviation limit	0.0%–100.0%	0.0%	☆
FA-10	PID differential limit	0.00%–100.00%	0.10%	☆
FA-11	PID setting change time	0.00–650.00s	0.00s	☆
FA-12	PID feedback filter time	0.00–60.00s	0.00s	☆
FA-13	PID output filter time	0.00–60.00s	0.00s	☆
FA-14	Reserved	-	-	☆
FA-15	Proportional gain Kp2	0.0–100.0	20.0	☆
FA-16	Integral time Ti2	0.01–10.00s	2.00s	☆
FA-17	Differential time Td2	0.000–10.000s	0.000s	☆
FA-18	PID parameter switchover condition	0: No switchover 1: Switchover via DI 2: Automatic switchover based on deviation	0	☆
FA-19	PID parameter switchover deviation 1	0.0% to FA-20	20.0%	☆
FA-20	PID parameter switchover deviation 2	FA-19 to 100.0%	80.0%	☆
FA-21	PID initial value	0.0%–100.0%	0.0%	☆
FA-22	PID initial value holding time	0.00–650.00s	0.00s	☆
FA-23	Maximum deviation between two PID outputs in forward direction	0.00%–100.00%	1.00%	☆

Function Code	Parameter Name	Setting Range	Default	Property
FA-24	Maximum deviation between two PID outputs in reverse direction	0.00%–100.00%	1.00%	☆
FA-25	PID integral property	Unit's digit (Integral separated)	00	☆
		0: Invalid 1: Valid		
		Ten's digit (Whether to stop integral operation when the output reaches the limit)		
		0: Continue integral operation 1: Stop integral operation		
FA-26	Detection value of PID feedback loss	0.0%: Not judging feedback loss 0.1%–100.0%	0.0%	☆
FA-27	Detection time of PID feedback loss	0.0–20.0s	0.0s	☆
FA-28	PID operation at stop	0: No PID operation at stop 1: PID operation at stop	0	☆
Group FB: Swing Frequency, Fixed Length and Count				
FB-00	Swing frequency setting mode	0: Relative to the central frequency 1: Relative to the maximum frequency	0	☆
FB-01	Swing frequency amplitude	0.0%–100.0%	0.0%	☆
FB-02	Jump frequency amplitude	0.0%–50.0%	0.0%	☆
FB-03	Swing frequency cycle	0.0–3000.0s	10.0s	☆
FB-04	Triangular wave rising time coefficient	0.0%–100.0%	50.0%	☆
FB-05	Set length	0–65535 m	1000 m	☆
FB-06	Actual length	0–65535 m	0 m	☆
FB-07	Number of pulses per meter	0.1–6553.5	100.0	☆
FB-08	Set count value	1–65535	1000	☆
FB-09	Designated count value	1–65535	1000	☆
Group FC: Multi-Reference and Simple PLC Function				
FC-00	Reference 0	-100.0%–100.0%	0.0%	☆
FC-01	Reference 1	-100.0%–100.0%	0.0%	☆
FC-02	Reference 2	-100.0%–100.0%	0.0%	☆
FC-03	Reference 3	-100.0%–100.0%	0.0%	☆
FC-04	Reference 4	-100.0%–100.0%	0.0%	☆

Function Code	Parameter Name	Setting Range	Default	Property
FC-05	Reference 5	-100.0%–100.0%	0.0%	☆
FC-06	Reference 6	-100.0%–100.0%	0.0%	☆
FC-07	Reference 7	-100.0%–100.0%	0.0%	☆
FC-08	Reference 8	-100.0%–100.0%	0.0%	☆
FC-09	Reference 9	-100.0%–100.0%	0.0%	☆
FC-10	Reference 10	-100.0%–100.0%	0.0%	☆
FC-11	Reference 11	-100.0%–100.0%	0.0%	☆
FC-12	Reference 12	-100.0%–100.0%	0.0%	☆
FC-13	Reference 13	-100.0%–100.0%	0.0%	☆
FC-14	Reference 14	-100.0%–100.0%	0.0%	☆
FC-15	Reference 15	-100.0%–100.0%	0.0%	☆
FC-16	Simple PLC running mode	0: Stop after the AC drive runs one cycle 1: Keep final values after the AC drive runs one cycle 2: Repeat after the AC drive runs one cycle	0	☆
FC-17	Simple PLC retentive selection	Unit's digit (Retentive upon power failure)	00	☆
		0: No 1: Yes		
		Ten's digit (Retentive upon stop)		
		0: No 1: Yes		
FC-18	Running time of simple PLC reference 0	0.0–6553.5s (h)	0.0s (h)	☆
FC-19	Acceleration/deceleration time of simple PLC reference 0	0–3	0	☆
FC-20	Running time of simple PLC reference 1	0.0–6553.5s (h)	0.0s (h)	☆
FC-21	Acceleration/deceleration time of simple PLC reference 1	0–3	0	☆
FC-22	Running time of simple PLC reference 2	0.0–6553.5s (h)	0.0s (h)	☆
FC-23	Acceleration/deceleration time of simple PLC reference 2	0–3	0	☆
FC-24	Running time of simple PLC reference 3	0.0–6553.5s (h)	0.0s (h)	☆
FC-25	Acceleration/deceleration time of simple PLC reference 3	0–3	0	☆



Function Code	Parameter Name	Setting Range	Default	Property
FC-26	Running time of simple PLC reference 4	0.0–6553.5s (h)	0.0s (h)	☆
FC-27	Acceleration/deceleration time of simple PLC reference 4	0–3	0	☆
FC-28	Running time of simple PLC reference 5	0.0–6553.5s (h)	0.0s (h)	☆
FC-29	Acceleration/deceleration time of simple PLC reference 5	0–3	0	☆
FC-30	Running time of simple PLC reference 6	0.0–6553.5s (h)	0.0s (h)	☆
FC-31	Acceleration/deceleration time of simple PLC reference 6	0–3	0	☆
FC-32	Running time of simple PLC reference 7	0.0–6553.5s (h)	0.0s (h)	☆
FC-33	Acceleration/deceleration time of simple PLC reference 7	0–3	0	☆
FC-34	Running time of simple PLC reference 8	0.0–6553.5s (h)	0.0s (h)	☆
FC-35	Acceleration/deceleration time of simple PLC reference 8	0–3	0	☆
FC-36	Running time of simple PLC reference 9	0.0–6553.5s (h)	0.0s (h)	☆
FC-37	Acceleration/deceleration time of simple PLC reference 9	0–3	0	☆
FC-38	Running time of simple PLC reference 10	0.0–6553.5s (h)	0.0s (h)	☆
FC-39	Acceleration/deceleration time of simple PLC reference 10	0–3	0	☆
FC-40	Running time of simple PLC reference 11	0.0–6553.5s (h)	0.0s (h)	☆
FC-41	Acceleration/deceleration time of simple PLC reference 11	0–3	0	☆
FC-42	Running time of simple PLC reference 12	0.0–6553.5s (h)	0.0s (h)	☆
FC-43	Acceleration/deceleration time of simple PLC reference 12	0–3	0	☆
FC-44	Running time of simple PLC reference 13	0.0–6553.5s (h)	0.0s (h)	☆
FC-45	Acceleration/deceleration time of simple PLC reference 13	0–3	0	☆
FC-46	Running time of simple PLC reference 14	0.0–6553.5s (h)	0.0s (h)	☆

Function Code	Parameter Name	Setting Range	Default	Property
FC-47	Acceleration/deceleration time of simple PLC reference 14	0–3	0	☆
FC-48	Running time of simple PLC reference 15	0.0–6553.5s (h)	0.0s (h)	☆
FC-49	Acceleration/deceleration time of simple PLC reference 15	0–3	0	☆
FC-50	Time unit of simple PLC running	0: s (second)1:h (hour)	0	☆
FC-51	Reference 0 source	0: Set by FC-00 1: AI1 2: AI2 3: AI3 4: Pulse setting 5: PID 6: Set by preset frequency (F0-08), modified via terminal UP/DOWN	0	☆

Function Code	Parameter Name	Setting Range	Default	Property				
Group FD: Communication Parameters								
FD-00	Baud rate	Unit's digit (Modbus baud rate)	6005	☆				
		0: 300 BPs 1: 600 BPs 2: 1200 BPs 3: 2400 BPs 4: 4800 BPs 5: 9600 BPs 6: 19200 BPs 7: 38400 BPs 8: 57600 BPs 9: 115200 BPs						
		Ten's digit (PROFIBUS-DP baud rate)						
		0: 115200 BPs 1: 208300 BPs 2: 256000 BPs 3: 512000 Bps						
		Hundred's digit (reserved)						
		Thousand's digit (CANlink baud rate)						
FD-01	Data format	0: No check, data format <8,N,2> 1: Even parity check, data format <8,E,1> 2: Odd Parity check, data format <8,O,1> 3: No check, data format <8,N,1> Valid for Modbus	0	☆				
		FD-02			Local address	0: Broadcast address 1-247 Valid for Modbus, PROFIBUS-DP and CANlink	1	☆

Function Code	Parameter Name	Setting Range	Default	Property
FD-03	Response delay	0–20 ms Valid for Modbus	2 ms	☆
FD-04	Communication timeout	0.0s (invalid) 0.1–60.0s Valid for Modbus, PROFIBUS-DP and CANopen	0.0s	☆
FD-05	Modbus protocol selection and PROFIBUS-DP data format	Unit's digit: Modbus protocol	30	☆
		0: Non-standard Modbus protocol 1: Standard Modbus protocol		
		Ten's digit: PROFIBUS-DP data format		
		0: PPO1 format 1: PPO2 format 2: PPO3 format 3: PPO5 format		
FD-06	Communication reading current resolution	0: 0.01A 1: 0.1A	0	☆
FD-08	CANlink communication timeout time	0.0s: Invalid 0.1–60.0s	0	☆
<b>Group FE: User-defined Parameters</b>				
FE-00	User-defined function code 0	F0-00 to FP-xx A0-00 to Ax-xx U0-xx to U0-xx	F0-10	☆
FE-01	User-defined function code 1		F0-02	☆
FE-02	User-defined function code 2		F0-03	☆
FE-03	User-defined function code 3		F0-07	☆
FE-04	User-defined function code 4		F0-08	☆
FE-05	User-defined function code 5		F0-17	☆
FE-06	User-defined function code 6		F0-18	☆
FE-07	User-defined function code 7		F3-00	☆
FE-08	User-defined function code 8		F3-01	☆
FE-09	User-defined function code 9		F4-00	☆
FE-10	User-defined function code 10		F4-01	☆
FE-11	User-defined function code 11		F4-02	☆
FE-12	User-defined function code 12		F5-04	☆
FE-13	User-defined function code 13		F5-07	☆
FE-14	User-defined function code 14		F6-00	☆

Function Code	Parameter Name	Setting Range	Default	Property
FE-15	User-defined function code 15	F0-00 to FP-xx A0-00 to Ax-xx U0-xx to U0-xx	F6-10	☆
FE-16	User-defined function code 16		F0-00	☆
FE-17	User-defined function code 17		F0-00	☆
FE-18	User-defined function code 18		F0-00	☆
FE-19	User-defined function code 19		F0-00	☆
FE-20	User-defined function code 20		F0-00	☆
FE-21	User-defined function code 21		F0-00	☆
FE-22	User-defined function code 22		F0-00	☆
FE-23	User-defined function code 23		F0-00	☆
FE-24	User-defined function code 24		F0-00	☆
FE-25	User-defined function code 25		F0-00	☆
FE-26	User-defined function code 26		F0-00	☆
FE-27	User-defined function code 27		F0-00	☆
FE-28	User-defined function code 28		F0-00	☆
FE-29	User-defined function code 29	F0-00	☆	
<b>Group FP: Function Code Management</b>				
FP-00	User password	0–65535	0	☆
FP-01	Restore default settings	0: No operation 01: Restore factory settings except motor parameters 02: Clear records 04: Restore user backup parameters 501: Back up current user parameters	0	★
FP-02	AC drive parameter display property	Unit's digit (Group U display selection)	11	★
		0: Not display 1: Display		
		Ten's digit (Group A display selection)		
		0: Not display 1: Display		

Function Code	Parameter Name	Setting Range	Default	Property
FP-03	Individualized parameter display property	Unit's digit (User-defined parameter display selection)	00	☆
		0: Not display 1: Display		
		Ten's digit (User-modified parameter display selection)		
		0: Not display 1: Display		
FP-04	Parameter modification property	0: Modifiable 1: Not modifiable	0	☆
<b>Group A0: Torque Control and Restricting Parameters</b>				
A0-00	Speed/Torque control selection	0: Speed control 1: Torque control	0	★
A0-01	Torque setting source in torque control	0: Digital setting (A0-03) 1: AI1 2: AI2 3: AI3 4: Pulse setting (DI5) 5: Communication setting 6: MIN (AI1, AI2) 7: MAX (AI1, AI2) Full range of values 1–7 corresponds to the digital setting of A0-03.	0	★
A0-03	Torque digital setting in torque control	-200.0%–200.0%	150.0%	☆
A0-05	Forward maximum frequency in torque control	0.00 Hz to maximum frequency (F0-10)	50.00 Hz	☆
A0-06	Reverse maximum frequency in torque control	0.00 Hz to maximum frequency (F0-10)	50.00 Hz	☆
A0-07	Acceleration time in torque control	0.00–65000s	0.00s	☆
A0-08	Deceleration time in torque control	0.00–65000s	0.00s	☆
<b>Group A1: Virtual DI (VDI)/Virtual DO (VDO)</b>				
A1-00	VDI1 function selection	0–59	0	★
A1-01	VDI2 function selection	0–59	0	★
A1-02	VDI3 function selection	0–59	0	★
A1-03	VDI4 function selection	0–59	0	★

Function Code	Parameter Name	Setting Range	Default	Property
A1-04	VDI5 function selection	0-59	0	★
A1-05	VDI state setting mode	Unit's digit (VDI1)	00000	★
		0: Decided by state of VDOx 1: Decided by A1-06		
		Ten's digit (VDI2)		
		0, 1 (same as VDI1)		
		Hundred's digit (VDI3)		
		0, 1 (same as VDI1)		
		Thousand's digit (VDI4)		
		0, 1 (same as VDI1)		
		Ten thousand's digit (VDI5)		
0, 1 (same as VDI1)				
A1-06	VDI state selection	Unit's digit (VDI1)	00000	★
		0: Invalid 1: Valid		
		Ten's digit (VDI2)		
		0, 1 (same as VDI1)		
		Hundred's digit (VDI3)		
		0, 1 (same as VDI1)		
		Thousand's digit (VDI4)		
		0, 1 (same as VDI1)		
		Ten thousand's digit (VDI5)		
0, 1 (same as VDI1)				
A1-07	Function selection for AI1 used as DI	0-59	0	★
A1-08	Function selection for AI2 used as DI	0-59	0	★
A1-09	Function selection for AI3 used as DI	0-59	0	★
A1-10	State selection for AI used as DI	Unit's digit (AI1)	000	★
		0: High level valid 1: Low level valid		
		Ten's digit (AI2)		
		0, 1 (same as unit's digit)		
		Hundred's digit (AI3)		
		0, 1 (same as unit's digit)		

Function Code	Parameter Name	Setting Range	Default	Property
A1-11	VDO1 function selection	0: Short with physical Dlx internally 1-40: Refer to function selection of physical DO in group F5.	0	☆
A1-12	VDO2 function selection	0: Short with physical Dlx internally 1-40: Refer to function selection of physical DO in group F5.	0	☆
A1-13	VDO3 function selection	0: Short with physical Dlx internally 1-40: Refer to function selection of physical DO in group F5.	0	☆
A1-14	VDO4 function selection	0: Short with physical Dlx internally 1-40: Refer to function selection of physical DO in group F5.	0	☆
A1-15	VDO5 function selection	0: Short with physical Dlx internally 1-40: Refer to function selection of physical DO in group F5.	0	☆
A1-16	VDO1 output delay	0.0-3600.0s	0.0s	☆
A1-17	VDO2 output delay	0.0-3600.0s	0.0s	☆
A1-18	VDO3 output delay	0.0-3600.0s	0.0s	☆
A1-19	VDO4 output delay	0.0-3600.0s	0.0s	☆
A1-20	VDO5 output delay	0.0-3600.0s	0.0s	☆
A1-21	VDO state selection	Unit's digit (VDO1)	00000	☆
		0: Positive logic 1: Reverse logic		
		Ten's digit (VDO2)		
		0, 1 (same as unit's digit)		
		Hundred's digit (VDO3)		
		0, 1 (same as unit's digit)		
		Thousand's digit (VDO4)		
		0, 1 (same as unit's digit)		
		Ten thousand's digit (VDO5)		
		0, 1 (same as unit's digit)		



Function Code	Parameter Name	Setting Range	Default	Property
Group A2: Motor 2 Parameters				
A2-00	Motor type selection	0: Common asynchronous motor 1: Variable frequency asynchronous motor 2: Permanent magnetic synchronous motor	0	★
A2-01	Rated motor power	0.1–1000.0 kW	Model dependent	★
A2-02	Rated motor voltage	1–2000 V	Model dependent	★
A2-03	Rated motor current	0.01–655.35 A (AC drive power ≤ 55 kW) 0.1–6553.5 A (AC drive power > 55 kW)	Model dependent	★
A2-04	Rated motor frequency	0.01 Hz to maximum frequency	Model dependent	★
A2-05	Rated motor rotational speed	1–65535 RPM	Model dependent	★
A2-06	Stator resistance (asynchronous motor)	0.001–65.535 Ω (AC drive power ≤ 55 kW) 0.0001–6.5535 Ω (AC drive power > 55 kW)	Model dependent	★
A2-07	Rotor resistance (asynchronous motor)	0.001–65.535 Ω (AC drive power ≤ 55 kW) 0.0001–6.5535 Ω (AC drive power > 55 kW)	Model dependent	★
A2-08	Leakage inductive reactance (asynchronous motor)	0.01–655.35 mH (AC drive power ≤ 55 kW) 0.001–65.535 mH (AC drive power > 55 kW)	Model dependent	★
A2-09	Mutual inductive reactance (asynchronous motor)	0.1–6553.5 mH (AC drive power ≤ 55 kW) 0.01–655.35 mH (AC drive power > 55 kW)	Model dependent	★
A2-10	No-load current (asynchronous motor)	0.01 A to A2-03 (AC drive power ≤ 55 kW) 0.1 A to A2-03 (AC drive power > 55 kW)	Model dependent	★
A2-16	Stator resistance (synchronous motor)	0.001–65.535 Ω (AC drive power ≤ 55 kW) 0.0001–6.5535 Ω (AC drive power > 55 kW)	Model dependent	★

Function Code	Parameter Name	Setting Range	Default	Property
A2-17	Shaft D inductance (synchronous motor)	0.01–655.35 mH (AC drive power ≤ 55 kW) 0.001–65.535 mH (AC drive power > 55 kW)	Model dependent	★
A2-18	Shaft Q inductance (synchronous motor)	0.01–655.35 mH (AC drive power ≤ 55 kW) 0.001–65.535 mH (AC drive power > 55 kW)	Model dependent	★
A2-20	Back EMF (synchronous motor)	0.1–6553.5 V	Model dependent	★
A2-27	Encoder pulses per revolution	1–65535	1024	★
A2-28	Encoder type	0: ABZ incremental encoder 1: UVW incremental encoder 2: Resolver 3: SIN/COS encoder 4: Wire-saving UVW encoder	0	★
A2-30	A, B phase sequence of ABZ incremental encoder	0: Forward 1: Reserve	0	★
A2-31	Encoder installation angle	0.0°–359.9°	0.0°	★
A2-32	U, V, W phase sequence of UVW encoder	0: Forward 1: Reverse	0	★
A2-33	UVW encoder angle offset	0.0°–359.9°	0.0°	★
A2-34	Number of pole pairs of resolver	1–65535	1	★
A2-36	Encoder wire-break fault detection time	0.0s: No action 0.1–10.0s	0.0s	★
A2-37	Auto-tuning selection	0: No auto-tuning 1: Asynchronous motor static auto-tuning 2: Asynchronous motor complete auto-tuning 11: Synchronous motor with-load auto-tuning 12: Synchronous motor no-load auto-tuning	0	★
A2-38	Speed loop proportional gain 1	0–100	30	☆
A2-39	Speed loop integral time 1	0.01–10.00s	0.50s	☆
A2-40	Switchover frequency 1	0.00 to A2-43	5.00 Hz	☆
A2-41	Speed loop proportional gain 2	0–100	15	☆

Function Code	Parameter Name	Setting Range	Default	Property
A2-42	Speed loop integral time 2	0.01–10.00s	1.00s	☆
A2-43	Switchover frequency 2	A2-40 to maximum output frequency	10.00 Hz	☆
A2-44	Vector control slip gain	50%–200%	100%	☆
A2-45	Time constant of speed loop filter	0.000–0.100s	0.000s	☆
A2-46	Vector control over-excitation gain	0–200	64	☆
A2-47	Torque upper limit source in speed control mode	0: A2-48 1: AI1 2: AI2 3: AI3 4: Pulse setting (DI5) 5: Via communication 6: MIN(AI1,AI2) 7: MIN(AI1,AI2)	0	☆
A2-48	Digital setting of torque upper limit in speed control mode	0.0%–200.0%	150.0%	☆
A2-51	Excitation adjustment proportional gain	0–20000	2000	☆
A2-52	Excitation adjustment integral gain	0–20000	1300	☆
A2-53	Torque adjustment proportional gain	0–20000	2000	☆
A2-54	Torque adjustment integral gain	0–20000	1300	☆
A2-55	Speed loop integral property	Unit's digit: Integral separated 0: Disabled 1: Enabled	0	☆
A2-56	Field weakening mode of synchronous motor	0: No field weakening 1: Direct calculation 2: Adjustment	0	☆
A2-57	Field weakening degree of synchronous motor	50%–500%	100%	☆
A2-58	Maximum field weakening current	1%–300%	50%	☆
A2-59	Field weakening automatic adjustment gain	10%–500%	100%	☆
A2-60	Field weakening integral multiple	2–10	2	☆

Function Code	Parameter Name	Setting Range	Default	Property
A2-61	Motor 2 control mode	0: Sensorless flux vector control (SFVC) 1: Closed-loop vector control (CLVC) 2: Voltage/Frequency (V/F) control	0	☆
A2-62	Motor 2 acceleration/ deceleration time	0: Same as motor 1 1: Acceleration/Deceleration time 1 2: Acceleration/Deceleration time 2 3: Acceleration/Deceleration time 3 4: Acceleration/Deceleration time 4	0	☆
A2-63	Motor 2 torque boost	0.0%: Automatic torque boost 0.1%–30.0%	Model dependent	☆
A2-65	Motor 2 oscillation suppression gain	0–100	Model dependent	☆
<b>Group A3: Motor 3 Parameters</b>				
A3-00	Motor type selection	0: Common asynchronous motor 1: Variable frequency asynchronous motor 2: Permanent magnetic synchronous motor	0	★
A3-01	Rated motor power	0.1–1000.0 kW	Model dependent	★
A3-02	Rated motor voltage	1–2000 V	Model dependent	★
A3-03	Rated motor current	0.01–655.35 A (AC drive power ≤ 55 kW) 0.1–6553.5 A (AC drive power > 55 kW)	Model dependent	★
A3-04	Rated motor frequency	0.01 Hz to maximum frequency	Model dependent	★
A3-05	Rated motor rotational speed	1–65535 RPM	Model dependent	★
A3-06	Stator resistance (asynchronous motor)	0.001–65.535 Ω (AC drive power ≤ 55 kW) 0.0001–6.5535 Ω (AC drive power > 55 kW)	Model dependent	★
A3-07	Rotor resistance (asynchronous motor)	0.001–65.535 Ω (AC drive power ≤ 55 kW) 0.0001–6.5535 Ω (AC drive power > 55 kW)	Model dependent	★

Function Code	Parameter Name	Setting Range	Default	Property
A3-08	Leakage inductive reactance (asynchronous motor)	0.01–655.35 mH (AC drive power ≤ 55 kW) 0.001–65.535 mH (AC drive power > 55 kW)	Model dependent	★
A3-09	Mutual inductive reactance (asynchronous motor)	0.1–6553.5 mH (AC drive power ≤ 55 kW) 0.01–655.35 mH (AC drive power > 55 kW)	Model dependent	★
A3-10	No-load current (asynchronous motor)	0.01 A to A2-03 (AC drive power ≤ 55 kW) 0.1 A to A2-03 (AC drive power > 55 kW)	Model dependent	★
A3-16	Stator resistance (synchronous motor)	0.001–65.535 Ω (AC drive power ≤ 55 kW) 0.0001–6.5535 Ω (AC drive power > 55 kW)	Model dependent	★
A3-17	Shaft D inductance (synchronous motor)	0.01–655.35 mH (AC drive power ≤ 55 kW) 0.001–65.535 mH (AC drive power > 55 kW)	Model dependent	★
A3-18	Shaft Q inductance (synchronous motor)	0.01–655.35 mH (AC drive power ≤ 55 kW) 0.001–65.535 mH (AC drive power > 55 kW)	Model dependent	★
A3-20	Back EMF (synchronous motor)	0.1–6553.5 V	Model dependent	★
A3-27	Encoder pulses per revolution	1–65535	1024	★
A3-28	Encoder type	0: ABZ incremental encoder 1: UVW incremental encoder 2: Resolver 3: SIN/COS encoder 4: Wire-saving UVW encoder	0	★
A3-30	A, B phase sequence of ABZ incremental encoder	0: Forward 1: Reserve	0	★
A3-31	Encoder installation angle	0.0°–359.9°	0.0°	★
A3-32	U, V, W phase sequence of UVW encoder	0: Forward 1: Reverse	0	★
A3-33	UVW encoder angle offset	0.0°–359.9°	0.0°	★

Function Code	Parameter Name	Setting Range	Default	Property
A3-34	Number of pole pairs of resolver	1–65535	1	★
A3-36	Encoder wire-break fault detection time	0.0s: No action 0.1–10.0s	0.0s	★
A3-37	Auto-tuning selection	0: No auto-tuning 1: Asynchronous motor static auto-tuning 2: Asynchronous motor complete auto-tuning 11: Synchronous motor with-load auto-tuning 12: Synchronous motor no-load auto-tuning	0	★
A3-38	Speed loop proportional gain 1	0–100	30	☆
A3-39	Speed loop integral time 1	0.01–10.00s	0.50s	☆
A3-40	Switchover frequency 1	0.00 to A2-43	5.00 Hz	☆
A3-41	Speed loop proportional gain 2	0–100	15	☆
A3-42	Speed loop integral time 2	0.01–10.00s	1.00s	☆
A3-43	Switchover frequency 2	A2-40 to maximum output frequency	10.00 Hz	☆
A3-44	Vector control slip gain	50%–200%	100%	☆
A3-45	Time constant of speed loop filter	0.000–0.100s	0.000s	☆
A3-46	Vector control over-excitation gain	0–200	64	☆
A3-47	Torque upper limit source in speed control mode	0: A2-48 1: AI1 2: AI2 3: AI3 4: Pulse setting (DI5) 5: Via communication 6: MIN (AI1,AI2) 7: MAX (AI1,AI2)	0	☆
A3-48	Digital setting of torque upper limit in speed control mode	0.0%–200.0%	150.0%	☆
A3-51	Excitation adjustment proportional gain	0–20000	2000	☆
A3-52	Excitation adjustment integral gain	0–20000	1300	☆

Function Code	Parameter Name	Setting Range	Default	Property
A3-53	Torque adjustment proportional gain	0–20000	2000	☆
A3-54	Torque adjustment integral gain	0–20000	1300	☆
A3-55	Speed loop integral property	Unit's digit: Integral separated 0: Disabled 1: Enabled	0	☆
A3-56	Field weakening mode of synchronous motor	0: No field weakening 1: Direct calculation 2: Adjustment	0	☆
A3-57	Field weakening degree of synchronous motor	50%–500%	100%	☆
A3-58	Maximum field weakening current	1%–300%	50%	☆
A3-59	Field weakening automatic adjustment gain	10%–500%	100%	☆
A3-60	Field weakening integral multiple	2–10	2	☆
A3-61	Motor 2 control mode	0: Sensorless flux vector control (SFVC) 1: Closed-loop vector control (CLVC) 2: Voltage/Frequency (V/F) control	0	☆
A3-62	Motor 2 acceleration/ deceleration time	0: Same as motor 1 1: Acceleration/Deceleration time 1 2: Acceleration/Deceleration time 2 3: Acceleration/Deceleration time 3 4: Acceleration/Deceleration time 4	0	☆
A3-63	Motor 2 torque boost	0.0%: Automatic torque boost 0.1%–30.0%	Model dependent	☆
A3-65	Motor 2 oscillation suppression gain	0–100	Model dependent	☆
<b>Group A4: Motor 4 Parameters</b>				
A4-00	Motor type selection	0: Common asynchronous motor 1: Variable frequency asynchronous motor 2: Permanent magnetic synchronous motor	0	★
A4-01	Rated motor power	0.1–1000.0 kW	Model dependent	★

Function Code	Parameter Name	Setting Range	Default	Property
A4-02	Rated motor voltage	1–2000 V	Model dependent	★
A4-03	Rated motor current	0.01–655.35 A (AC drive power ≤ 55 kW) 0.1–6553.5 A (AC drive power > 55 kW)	Model dependent	★
A4-04	Rated motor frequency	0.01 Hz to maximum frequency	Model dependent	★
A4-05	Rated motor rotational speed	1–65535 RPM	Model dependent	★
A4-06	Stator resistance (asynchronous motor)	0.001–65.535 Ω (AC drive power ≤ 55 kW) 0.0001–6.5535 Ω (AC drive power > 55 kW)	Model dependent	★
A4-07	Rotor resistance (asynchronous motor)	0.001–65.535 Ω (AC drive power ≤ 55 kW) 0.0001–6.5535 Ω (AC drive power > 55 kW)	Model dependent	★
A4-08	Leakage inductive reactance (asynchronous motor)	0.01–655.35 mH (AC drive power ≤ 55 kW) 0.001–65.535 mH (AC drive power > 55 kW)	Model dependent	★
A4-09	Mutual inductive reactance (asynchronous motor)	0.1–6553.5 mH (AC drive power ≤ 55 kW) 0.01–655.35 mH (AC drive power > 55 kW)	Model dependent	★
A4-10	No-load current (asynchronous motor)	0.01 A to A2-03 (AC drive power ≤ 55 kW) 0.1 A to A2-03 (AC drive power > 55 kW)	Model dependent	★
A4-16	Stator resistance (synchronous motor)	0.001–65.535 Ω (AC drive power ≤ 55 kW) 0.0001–6.5535 Ω (AC drive power > 55 kW)	Model dependent	★
A4-17	Shaft D inductance (synchronous motor)	0.01–655.35 mH (AC drive power ≤ 55 kW) 0.001–65.535 mH (AC drive power > 55 kW)	Model dependent	★
A4-18	Shaft Q inductance (synchronous motor)	0.01–655.35 mH (AC drive power ≤ 55 kW) 0.001–65.535 mH (AC drive power > 55 kW)	Model dependent	★



Function Code	Parameter Name	Setting Range	Default	Property
A4-20	Back EMF (synchronous motor)	0.1–6553.5 V	Model dependent	★
A4-27	Encoder pulses per revolution	1–65535	1024	★
A4-28	Encoder type	0: ABZ incremental encoder 1: UVW incremental encoder 2: Resolver 3: SIN/COS encoder 4: Wire-saving UVW encoder	0	★
A4-30	A, B phase sequence of ABZ incremental encoder	0: Forward 1: Reserve	0	★
A4-31	Encoder installation angle	0.0°–359.9°	0.0°	★
A4-32	U, V, W phase sequence of UVW encoder	0: Forward 1: Reverse	0	★
A4-33	UVW encoder angle offset	0.0°–359.9°	0.0°	★
A4-34	Number of pole pairs of resolver	1–65535	1	★
A4-36	Encoder wire-break fault detection time	0.0s: No action 0.1–10.0s	0.0s	★
A4-37	Auto-tuning selection	0: No auto-tuning 1: Asynchronous motor static auto-tuning 2: Asynchronous motor complete auto-tuning 11: Synchronous motor with-load auto-tuning 12: Synchronous motor no-load auto-tuning	0	★
A4-38	Speed loop proportional gain 1	0–100	30	☆
A4-39	Speed loop integral time 1	0.01–10.00s	0.50s	☆
A4-40	Switchover frequency 1	0.00 to A2-43	5.00 Hz	☆
A4-41	Speed loop proportional gain 2	0–100	15	☆
A4-42	Speed loop integral time 2	0.01–10.00s	1.00s	☆
A4-43	Switchover frequency 2	A2-40 to maximum output frequency	10.00 Hz	☆
A4-44	Vector control slip gain	50%–200%	100%	☆
A4-45	Time constant of speed loop filter	0.000–0.100s	0.000s	☆

Function Code	Parameter Name	Setting Range	Default	Property
A4-46	Vector control over-excitation gain	0–200	64	☆
A4-47	Torque upper limit source in speed control mode	0: A2-48 1: AI1 2: AI2 3: AI3 4: Pulse setting (DI5) 5: Via communication 6: MIN(AI1,AI2) 7: MIN(AI1,AI2)	0	☆
A4-48	Digital setting of torque upper limit in speed control mode	0.0%–200.0%	150.0%	☆
A4-51	Excitation adjustment proportional gain	0–20000	2000	☆
A4-52	Excitation adjustment integral gain	0–20000	1300	☆
A4-53	Torque adjustment proportional gain	0–20000	2000	☆
A4-54	Torque adjustment integral gain	0–20000	1300	☆
A4-55	Speed loop integral property	Unit's digit: Integral separated 0: Disabled 1: Enabled	0	☆
A4-56	Field weakening mode of synchronous motor	0: No field weakening 1: Direct calculation 2: Adjustment	0	☆
A4-57	Field weakening degree of synchronous motor	50%–500%	100%	☆
A4-58	Maximum field weakening current	1%–300%	50%	☆
A4-59	Field weakening automatic adjustment gain	10%–500%	100%	☆
A4-60	Field weakening integral multiple	2–10	2	☆
A4-61	Motor 2 control mode	0: Sensorless flux vector control (SFVC) 1: Closed-loop vector control (CLVC) 2: Voltage/Frequency (V/F) control	0	☆

Function Code	Parameter Name	Setting Range	Default	Property
A4-62	Motor 2 acceleration/ deceleration time	0: Same as motor 1 1: Acceleration/Deceleration time 1 2: Acceleration/Deceleration time 2 3: Acceleration/Deceleration time 3 4: Acceleration/Deceleration time 4	0	☆
A4-63	Motor 2 torque boost	0.0%: Automatic torque boost 0.1%–30.0%	Model dependent	☆
A4-65	Motor 2 oscillation suppression gain	0–100	Model dependent	☆
<b>Group A5: Control Optimization Parameters</b>				
A5-00	DPWM switchover frequency upper limit	0.00–15.00 Hz	12.00 Hz	☆
A5-01	PWM modulation mode	0: Asynchronous modulation 1: Synchronous modulation	0	☆
A5-02	Dead zone compensation mode selection	0: No compensation 1: Compensation mode 1 2: Compensation mode 2	1	☆
A5-03	Random PWM depth	0: Random PWM invalid 1–10	0	☆
A5-04	Rapid current limit	0: Disabled 1: Enabled	1	☆
A5-05	Current detection compensation	0–100	5	☆
A5-06	Undervoltage threshold	60.0%–140.0%	100.0%	☆
A5-07	SFVC optimization mode selection	0: No optimization 1: Optimization mode 1 2: Optimization mode 2	1	☆
A5-08	Dead-zone time adjustment	100%–200%	150%	☆
A5-09	Overvoltage threshold	200.0–2500.0 V	2000.0 V	☆
<b>Group A6: AI Curve Setting</b>				
A6-00	AI curve 4 minimum input	-10.00 V to A6-02	0.00 V	☆
A6-01	Corresponding setting of AI curve 4 minimum input	-100.0%–100.0%	0.0%	☆
A6-02	AI curve 4 inflexion 1 input	A6-00 to A6-04	3.00 V	☆
A6-03	Corresponding setting of AI curve 4 inflexion 1 input	-100.0%–100.0%	30.0%	☆
A6-04	AI curve 4 inflexion 1 input	A6-02 to A6-06	6.00 V	☆
A6-05	Corresponding setting of AI curve 4 inflexion 1 input	-100.0%–100.0%	60.0%	☆
A6-06	AI curve 4 maximum input	A6-06 to 10.00 V	10.00 V	☆

Function Code	Parameter Name	Setting Range	Default	Property
A6-07	Corresponding setting of AI curve 4 maximum input	-100.0%–100.0%	100.0%	☆
A6-08	AI curve 5 minimum input	-10.00 V to A6-10	0.00 V	☆
A6-09	Corresponding setting of AI curve 5 minimum input	-100.0%–100.0%	0.0%	☆
A6-10	AI curve 5 inflexion 1 input	A6-08 to A6-12	3.00 V	☆
A6-11	Corresponding setting of AI curve 5 inflexion 1 input	-100.0%–100.0%	30.0%	☆
A6-12	AI curve 5 inflexion 1 input	A6-10 to A6-14	6.00 V	☆
A6-13	Corresponding setting of AI curve 5 inflexion 1 input	-100.0%–100.0%	60.0%	☆
A6-14	AI curve 5 maximum input	A6-14 to 10.00 V	10.00 V	☆
A6-15	Corresponding setting of AI curve 5 maximum input	-100.0%–100.0%	100.0%	☆
A6-16	Jump point of AI1 input corresponding setting	-100.0%–100.0%	0.0%	☆
A6-17	Jump amplitude of AI1 input corresponding setting	0.0%–100.0%	0.5%	☆
A6-18	Jump point of AI2 input corresponding setting	-100.0%–100.0%	0.0%	☆
A6-19	Jump amplitude of AI2 input corresponding setting	0.0%–100.0%	0.5%	☆
A6-20	Jump point of AI3 input corresponding setting	-100.0%–100.0%	0.0%	☆
A6-21	Jump amplitude of AI3 input corresponding setting	0.0%–100.0%	0.5%	☆
<b>Group A7: User Programmable Function</b>				
A7-00	User programmable function selection	0: Disabled 1: Enabled	0	★

Function Code	Parameter Name	Setting Range	Default	Property
A7-01	Selection of control mode of the output terminals on the control board	Unit's digit: FMR (FM used as digital output)	0	★
		0: Controlled by the AC drive 1: Controlled by the user programmable card		
		Ten's digit: relay (T/A-T/B-T/C)		
		Same as unit's digit		
		Hundred's digit: DO1		
		Same as unit's digit		
		Thousand's digit FMR (FM used as pulse output)		
		Same as unit's digit		
		Ten thousand's digit: AO1		
		Same as unit's digit		
A7-02	AI/AO function selection of the user programmable card	0: AI3 (voltage input), AO2 (voltage output)	0	★
		1: AI3 (voltage input), AO2 (current output)		
		2: AI3 (current input), AO2 (voltage output)		
		3: AI3 (current input), AO2 (current output)		
		4: AI3 (PTC input), AO2 (voltage output)		
		5: AI3 (PTC input), AO2 (current output)		
		6: AI3 (PTC100 input), AO2 (voltage output)		
		7: AI3 (PTC100 input), AO2 (current output)		
A7-03	FMP output	0.0%–100.0%	0.0%	☆
A7-04	AO1 output	0.0%–100.0%	0.0%	☆
A7-05	Digital output	Binary setting Unit's digit: FMR Ten's digit: Relay1 Hundred's digit: DO	1	☆
A7-06	Frequency setting through the user programmable card	-100.00% to 100.00%	0.0%	☆
A7-07	Torque setting through the user programmable card	-200.00% to 200.00%	0.0%	☆

Function Code	Parameter Name	Setting Range	Default	Property
A7-08	Command given by the user programmable card	1: Forward RUN 2: Reverse RUN 3: Forward JOG 4: Reverse JOG 5: Coast to stop 6: Decelerate to stop 7: Fault reset	0	☆
A7-09	Faults given by the user programmable card	0: No fault 80–89: Fault codes	0	☆
<b>Group A8: Point-point Communication</b>				
A8-00	Point-point communication selection	0: Disabled 1: Enabled	0	☆
A8-01	Master and slave selection	0: Master 1: Slave	0	☆
A8-02	Slave following master command selection	0: Slave not following running commands of the master 1: Slave following running commands of the master	0	☆
A8-03	Usage of data received by slave	0: Torque setting 1: Frequency setting	0	☆
A8-04	Zero offset of received data (torque)	-100.00%–100.00%	0.00%	★
A8-05	Gain of received data (torque)	-10.00–10.00	1.00	★
A8-06	Point-point communication interruption detection time	0.0–10.0s	1.0s	☆
A8-07	Master data sending cycle	0.001–10.000s	0.001s	☆
A8-08	Zero offset of received data zero offset (frequency)	-100.00%–100.00%	0.00%	★
A8-09	Gain of received data gain (frequency)	-10.00–10.00	1.00	★
A8-10	Runaway prevention coefficient	0.00%–100.00%	10.00%	★
<b>Group AC: AI/AO Correction</b>				
AC-00	AI1 measured voltage 1	0.500–4.000 V	Factory corrected	☆
AC-01	AI1 displayed voltage 1	0.500–4.000 V	Factory corrected	☆
AC-02	AI1 measured voltage 2	6.000–9.999 V	Factory corrected	☆

Function Code	Parameter Name	Setting Range	Default	Property
AC-03	AI1 displayed voltage 2	6.000–9.999 V	Factory corrected	☆
AC-04	AI2 measured voltage 1	0.500–4.000 V	Factory corrected	☆
AC-05	AI2 displayed voltage 1	0.500–4.000 V	Factory corrected	☆
AC-06	AI2 measured voltage 2	6.000–9.999 V	Factory corrected	☆
AC-07	AI2 displayed voltage 2	9.999–10.000 V	Factory corrected	☆
AC-08	AI3 measured voltage 1	9.999–10.000 V	Factory corrected	☆
AC-09	AI3 displayed voltage 1	9.999–10.000 V	Factory corrected	☆
AC-10	AI3 measured voltage 2	9.999–10.000 V	Factory corrected	☆
AC-11	AI3 displayed voltage 2	9.999–10.000 V	Factory corrected	☆
AC-12	AO1 target voltage 1	0.500–4.000 V	Factory corrected	☆
AC-13	AO1 measured voltage 1	0.500–4.000 V	Factory corrected	☆
AC-14	AO1 target voltage 2	6.000–9.999 V	Factory corrected	☆
AC-15	AO1 measured voltage 2	6.000–9.999 V	Factory corrected	☆
AC-16	AO2 target voltage 1	0.500–4.000 V	Factory corrected	☆
AC-17	AO2 measured voltage 1	0.500–4.000 V	Factory corrected	☆
AC-18	AO2 target voltage 2	6.000–9.999 V	Factory corrected	☆
AC-19	AO2 measured voltage 2	6.000–9.999 V	Factory corrected	☆
AC-20	AI2 measured current 1	0.000–20.000 mA	Factory corrected	☆
AC-21	AI2 sampling current 1	0.000–20.000 mA	Factory corrected	☆
AC-22	AI2 measured current 2	0.000–20.000 mA	Factory corrected	☆
AC-23	AI2 sampling current 2	0.000–20.000 mA	Factory corrected	☆

Function Code	Parameter Name	Setting Range	Default	Property
AC-24	AO1 ideal current 1	0.000–20.000 mA	Factory corrected	☆
AC-25	AO1 sampling current 1	0.000–20.000 mA	Factory corrected	☆
AC-26	AO1 ideal current 2	0.000–20.000 mA	Factory corrected	☆
AC-27	AO1 sampling current 2	0.000–20.000 mA	Factory corrected	☆

### 5.2 Monitoring Parameters

Function Code	Parameter Name	Min. Unit	Communication Address
Group U0: Standard Monitoring Parameters			
U0-00	Running frequency (Hz)	0.01 Hz	7000H
U0-01	Set frequency (Hz)	0.01 Hz	7001H
U0-02	Bus voltage	0.1 V	7002H
U0-03	Output voltage	1 V	7003H
U0-04	Output current	0.01 A	7004H
U0-05	Output power	0.1 kW	7005H
U0-06	Output torque	0.1%	7006H
U0-07	DI state	1	7007H
U0-08	DO state	1	7008H
U0-09	AI1 voltage (V)	0.01 V	7009H
U0-10	AI2 voltage (V)/current (mA)	0.01 V/0.01 mA	700AH
U0-11	AI3 voltage (V)	0.01 V	7007BH
U0-12	Count value	1	700CH
U0-13	Length value	1	700DH
U0-14	Load speed	1	700EH
U0-15	PID setting	1	700FH
U0-16	PID feedback	1	7010H
U0-17	PLC stage	1	7011H
U0-18	Input pulse frequency (Hz)	0.01 kHz	7012H
U0-19	Feedback speed	0.01 Hz	7013H
U0-20	Remaining running time	0.1 Min	7014H
U0-21	AI1 voltage before correction	0.001 V	7015H
U0-22	AI2 voltage (V)/current (mA) before correction	0.01 V/0.01 mA	7016H



Function Code	Parameter Name	Min. Unit	Communication Address
Group U0: Standard Monitoring Parameters			
U0-23	AI3 voltage before correction	0.001 V	7017H
U0-24	Linear speed	1 m/Min	7018H
U0-25	Accumulative power-on time	1 Min	7019
U0-26	Accumulative running time	0.1 Min	701AH
U0-27	Pulse input frequency	1 Hz	701BH
U0-28	Communication setting value	0.01%	701CH
U0-29	Encoder feedback speed	0.01 Hz	701DH
U0-30	Main frequency X	0.01 Hz	701EH
U0-31	Auxiliary frequency Y	0.01 Hz	701FH
U0-32	Viewing any register address value	1	7020H
U0-33	Synchronous motor rotor position	0.1°	7021H
U0-34	Motor temperature	1°C	7022H
U0-35	Target torque	0.1%	7023H
U0-36	Resolver position	1	7024H
U0-37	Power factor angle	0.1°	7025H
U0-38	ABZ position	1	7026H
U0-39	Target voltage upon V/F separation	1 V	7027H
U0-40	Output voltage upon V/F separation	1V	7028H
U0-41	DI state visual display	1	7029H
U0-42	DO state visual display	1	702AH
U0-43	DI function state visual display 1	1	702BH
U0-44	DI function state visual display 2	1	702CH
U0-45	Fault information	1	702DH
U0-58	Phase Z counting	1	703AH
U0-59	Current set frequency	0.01%	703BH
U0-60	Current running frequency	0.01%	703CH
U0-61	AC drive running state	1	703DH
U0-62	Current fault code	1	703EH
U0-63	Sent value of point-point communication	0.01%	703FH
U0-64	Received value of point-point communication	0.01%	7040H
U0-65	Torque upper limit	0.1%	7041H



## **Maintenance and Troubleshooting**

---

## Chapter 2 Maintenance and Troubleshooting

### 9.1 Routine Repair and Maintenance of the ETAKE

#### 9.1.1 Routine Maintenance

The influence of the ambient temperature, humidity, dust and vibration will cause the aging of the devices in the AC drive, which may cause potential faults or reduce the service life of the AC drive. Therefore, it is necessary to carry out routine and periodic maintenance.

Routine maintenance involves checking:

- Whether the motor sounds abnormally during running
- Whether the motor vibrates excessively during running
- Whether the installation environment of the AC drive changes.
- Whether the AC drive's cooling fan works normally
- Whether the AC drive overheats

Routine cleaning involves:

- Keep the AC drive clean all the time.
- Remove the dust, especially metal powder on the surface of the AC drive, to prevent the dust from entering the AC drive.
- Clear the oil stain on the cooling fan of the AC drive.

#### 9.1.2 Periodic Inspection

Perform periodic inspection in places where inspection is difficult.

Periodic inspection involves:

Check and clean the air duct periodically.

Check whether the screws become loose.

Check whether the AC drive is corroded.

Check whether the wiring terminals show signs of arcing;

Main circuit insulation test

**Prompt**

Before measuring the insulating resistance with megameter (500 VDC megameter recommended), disconnect the main circuit from the AC drive. Do not use the insulating resistance meter to test the insulation of the control circuit. The high voltage test need not be performed again because it has been completed before delivery.



### 9.1.3 Replacement of Vulnerable Components

The vulnerable components of the AC drive are cooling fan and filter electrolytic capacitor. Their service life is related to the operating environment and maintenance status. Generally, the service life is shown as follows:

Component	Service Life	Possible Damage Reason	Judging Criteria
Fan	2 to 3 years	<ul style="list-style-type: none"> <li>• Bearing worn</li> <li>• Blade aging</li> </ul>	<ul style="list-style-type: none"> <li>• Whether there is crack on the blade</li> <li>• Whether there is abnormal vibration noise upon startup</li> </ul>
Electrolytic capacitor	4 to 5 years	<ul style="list-style-type: none"> <li>• Input power supply in poor quality</li> <li>• High ambient temperature</li> <li>• Frequent load jumping</li> <li>• Electrolytic aging</li> </ul>	<ul style="list-style-type: none"> <li>• Whether there is liquid leakage.</li> <li>• Whether the safe valve has projected.</li> <li>• Measure the static capacitance.</li> <li>• Measure the insulating resistance.</li> </ul>

### 9.1.4 Storage of the AC Drive

For storage of the AC drive, pay attention to the following two aspects:

- 1) Pack the AC drive with the original packing box provided by ETAKE.
- 2) Long-term storage degrades the electrolytic capacitor. Thus, the AC drive must be energized once every 2 years, each time lasting at least 5 hours. The input voltage must be increased slowly to the rated value with the regulator.

## 9.2 Warranty Agreement

- 1) Free warranty only applies to the AC drive itself.
- 2) ETAKE will provide 18-month warranty (starting from the leave-factory date as indicated on the barcode) for the failure or damage under normal use conditions. If the equipment has been used for over 18 months, reasonable repair expenses will be charged.
- 3) Reasonable repair expenses will be charged for the damages due to the following causes:
  - Improper operation without following the instructions
  - Fire, flood or abnormal voltage.
  - Using the AC drive for non-recommended function
- 4) The maintenance fee is charged according to ETAKE's uniform standard. If there is an agreement, the agreement prevails.

## 9.3 Faults and Solutions

The ETAKE provides a total of 24 pieces of fault information and protective functions. After a fault occurs, the AC drive implements the protection function, and displays the fault code on the operation panel (if the operation panel is available).

Before contacting ETAKE for technical support, you can first determine the fault type, analyze the causes, and perform troubleshooting according to the following tables. If the fault cannot be rectified, contact the agent or ETAKE.

Err22 is the AC drive hardware overcurrent or overvoltage signal. In most situations, hardware overvoltage fault causes Err22.

Figure 9-1 Solutions to the faults of the ETAKE

Fault Name	Display	Possible Causes	Solutions
Inverter unit protection	Err01	1: The output circuit is grounded or short circuited. 2: The connecting cable of the motor is too long. 3: The module overheats. 4: The internal connections become loose. 5: The main control board is faulty. 6: The drive board is faulty. 7: The inverter module is faulty.	1: Eliminate external faults. 2: Install a reactor or an output filter. 3: Check the air filter and the cooling fan. 4: Connect all cables properly. 5: Contact the agent or ETAKE.
Overcurrent during acceleration	Err02	1: The output circuit is grounded or short circuited. 2: Motor auto-tuning is not performed. 3: The acceleration time is too short. 4: Manual torque boost or V/F curve is not appropriate. 5: The voltage is too low. 6: The startup operation is performed on the rotating motor. 7: A sudden load is added during acceleration. 8: The AC drive model is of too small power class.	1: Eliminate external faults. 2: Perform the motor auto-tuning. 3: Increase the acceleration time. 4: Adjust the manual torque boost or V/F curve. 5: Adjust the voltage to normal range. 6: Select rotational speed tracking restart or start the motor after it stops. 7: Remove the added load. 8: Select an AC drive of higher power class.
Overcurrent during deceleration	Err03	1: The output circuit is grounded or short circuited. 2: Motor auto-tuning is not performed. 3: The deceleration time is too short. 4: The voltage is too low. 5: A sudden load is added during deceleration. 6: The braking unit and braking resistor are not installed.	1: Eliminate external faults. 2: Perform the motor auto-tuning. 3: Increase the deceleration time. 4: Adjust the voltage to normal range. 5: Remove the added load. 6: Install the braking unit and braking resistor.

Fault Name	Display	Possible Causes	Solutions
Overcurrent at constant speed	Err04	1: The output circuit is grounded or short circuited. 2: Motor auto-tuning is not performed. 3: The voltage is too low. 4: A sudden load is added during operation. 5: The AC drive model is of too small power class.	1: Eliminate external faults. 2: Perform the motor auto-tuning. 3: Adjust the voltage to normal range. 4: Remove the added load. 5: Select an AC drive of higher power class.
Overvoltage during acceleration	Err05	1: The input voltage is too high. 2: An external force drives the motor during acceleration. 3: The acceleration time is too short. 4: The braking unit and braking resistor are not installed.	1: Adjust the voltage to normal range. 2: Cancel the external force or install a braking resistor. 3: Increase the acceleration time. 4: Install the braking unit and braking resistor.
Overvoltage during deceleration	Err06	1: The input voltage is too high. 2: An external force drives the motor during deceleration. 3: The deceleration time is too short. 4: The braking unit and braking resistor are not installed.	1: Adjust the voltage to normal range. 2: Cancel the external force or install the braking resistor. 3: Increase the deceleration time. 4: Install the braking unit and braking resistor.
Overvoltage at constant speed	Err07	1: The input voltage is too high. 2: An external force drives the motor during deceleration.	1: Adjust the voltage to normal range. 2: Cancel the external force or install the braking resistor.
Control power supply fault	Err08	The input voltage is not within the allowable range.	Adjust the input voltage to the allowable range.
Undervoltage	Err09	1: Instantaneous power failure occurs on the input power supply. 2: The AC drive's input voltage is not within the allowable range. 3: The bus voltage is abnormal. 4: The rectifier bridge and buffer resistor are faulty. 5: The drive board is faulty. 6: The main control board is faulty.	1: Reset the fault. 2: Adjust the voltage to normal range. 3: Contact the agent or ETAKE.
AC drive overload	Err10	1: The load is too heavy or locked-rotor occurs on the motor. 2: The AC drive model is of too small power class.	1: Reduce the load and check the motor and mechanical condition. 2: Select an AC drive of higher power class.

Fault Name	Display	Possible Causes	Solutions
Motor overload	Err11	1: F9-01 is set improperly. 2: The load is too heavy or locked-rotor occurs on the motor. 3: The AC drive model is of too small power class.	1: Set F9-01 correctly. 2: Reduce the load and check the motor and the mechanical condition. 3: Select an AC drive of higher power class.
Power input phase loss	Err12	1: The three-phase power input is abnormal. 2: The drive board is faulty. 3: The lightning board is faulty. 4: The main control board is faulty.	1: Eliminate external faults. 2: Contact the agent or ETAKE.
Power output phase loss	Err13	1: The cable connecting the AC drive and the motor is faulty. 2: The AC drive's three-phase outputs are unbalanced when the motor is running. 3: The drive board is faulty. 4: The module is faulty.	1: Eliminate external faults. 2: Check whether the motor three-phase winding is normal. 3: Contact the agent or ETAKE.
Module overheat	Err14	1: The ambient temperature is too high. 2: The air filter is blocked. 3: The fan is damaged. 4: The thermally sensitive resistor of the module is damaged. 5: The inverter module is damaged.	1: Lower the ambient temperature. 2: Clean the air filter. 3: Replace the damaged fan. 4: Replace the damaged thermally sensitive resistor. 5: Replace the inverter module.
External equipment fault	Err15	1: External fault signal is input via DI. 2: External fault signal is input via virtual I/O.	Reset the operation.
Communication fault	Err16	1: The host computer is in abnormal state. 2: The communication cable is faulty. 3: F0-28 is set improperly. 4: The communication parameters in group FD are set improperly.	1: Check the cabling of host computer. 2: Check the communication cabling. 3: Set F0-28 correctly. 4: Set the communication parameters properly.
Contactors fault	Err17	1: The drive board and power supply are faulty. 2: The contactor is faulty.	1: Replace the faulty drive board or power supply board. 2: Replace the faulty contactor.

Fault Name	Display	Possible Causes	Solutions
Current detection fault	Err18	1: The HALL device is faulty. 2: The drive board is faulty.	1: Replace the faulty HALL device. 2: Replace the faulty drive board.
Motor auto-tuning fault	Err19	1: The motor parameters are not set according to the nameplate. 2: The motor auto-tuning times out.	1: Set the motor parameters according to the nameplate properly. 2: Check the cable connecting the AC drive and the motor.
Encoder fault	Err20	1: The encoder type is incorrect. 2: The cable connection of the encoder is incorrect. 3: The encoder is damaged. 4: The PG card is faulty.	1: Set the encoder type correctly based on the actual situation. 2: Eliminate external faults. 3: Replace the damaged encoder. 4: Replace the faulty PG card.
EEPROM read-write fault	Err21	The EEPROM chip is damaged.	Replace the main control board.
AC drive hardware fault	Err22	1: Overvoltage exists. 2: Overcurrent exists.	1: Handle based on overvoltage. 2: Handle based on overcurrent.
Short circuit to ground	Err23	The motor is short circuited to the ground.	Replace the cable or motor.
Accumulative running time reached	Err26	The accumulative running time reaches the setting value.	Clear the record through the parameter initialization function.
User-defined fault 1	Err27	1: The user-defined fault 1 signal is input via DI. 2: User-defined fault 1 signal is input via virtual I/O.	Reset the operation.
User-defined fault 2	Err28	1: The user-defined fault 2 signal is input via DI. 2: The user-defined fault 2 signal is input via virtual I/O.	Reset the operation.
Accumulative power-on time reached	Err29	The accumulative power-on time reaches the setting value.	Clear the record through the parameter initialization function.
Load becoming 0	Err30	The AC drive running current is lower than F9-64.	Check that the load is disconnected or the setting of F9-64 and F9-65 is correct.
PID feedback lost during running	Err31	The PID feedback is lower than the setting of FA-26.	Check the PID feedback signal or set FA-26 to a proper value.



Fault Name	Display	Possible Causes	Solutions
Pulse-by-pulse current limit fault	Err40	1: The load is too heavy or locked-rotor occurs on the motor. 2: The AC drive model is of too small power class.	1: Reduce the load and check the motor and mechanical condition. 2: Select an AC drive of higher power class.
Motor switchover fault during running	Err41	Change the selection of the motor via terminal during running of the AC drive.	Perform motor switchover after the AC drive stops.
Too large speed deviation	Err42	1: The encoder parameters are set incorrectly. 2: The motor auto-tuning is not performed. 3: F9-69 and F9-70 are set incorrectly.	1: Set the encoder parameters properly. 2: Perform the motor auto-tuning. 3: Set F9-69 and F9-70 correctly based on the actual situation.
Motor over-speed	Err43	1: The encoder parameters are set incorrectly. 2: The motor auto-tuning is not performed. 3: F9-69 and F9-70 are set incorrectly.	1: Set the encoder parameters properly. 2: Perform the motor auto-tuning. 3: Set F9-69 and F9-70 correctly based on the actual situation.
Motor overheat	Err45	1: The cabling of the temperature sensor becomes loose. 2: The motor temperature is too high.	1: Check the temperature sensor cabling and eliminate the cabling fault. 2: Lower the carrier frequency or adopt other heat radiation measures.
Initial position fault	Err51	The motor parameters are not set based on the actual situation.	Check that the motor parameters are set correctly and whether the setting of rated current is too small.

## 9.4 Common Faults and Solutions

You may come across the following faults during the use of the AC drive. Refer to the following table for simple fault analysis.

Table 9-2 Troubleshooting to common faults of the AC drive

SN	Fault	Possible Causes	Solutions
1	There is no display at power-on.	1: There is no power supply to the AC drive or the power input to the AC drive is too low. 2: The power supply of the switch on the drive board of the AC drive is faulty. 3: The rectifier bridge is damaged. 4: The control board or the operation panel is faulty. 5: The cable connecting the control board and the drive board and the operation panel breaks.	1: Check the power supply. 2: Check the bus voltage. 3: Re-connect the 8-core and 28-core cables. 4: Contact the agent or ETAKE for technical support.
2	"HC" is displayed at power-on.	1: The cable between the drive board and the control board is in poor contact. 2: Related components on the control board are damaged. 3: The motor or the motor cable is short circuited to the ground. 4: The HALL device is faulty. 5: The power input to the AC drive is too low.	1: Re-connect the 8-core and 28-core cables. 2: Contact the agent or ETAKE for technical support.
3	"Err23" is displayed at power-on.	1: The motor or the motor output cable is short-circuited to the ground. 2: The AC drive is damaged.	1: Measure the insulation of the motor and the output cable with a megger. 2: Contact the agent or ETAKE for technical support.
4	The AC drive display is normal upon power-on. But "HC" is displayed after running and stops immediately.	1: The cooling fan is damaged or locked-rotor occurs. 2: The external control terminal cable is short circuited.	1: Replace the damaged fan. 2: Eliminate external fault.
5	Err14 (module overheat) fault is reported frequently.	1: The setting of carrier frequency is too high. 2: The cooling fan is damaged, or the air filter is blocked. 3: Components inside the AC drive are damaged (thermal coupler or others).	1: Reduce the carrier frequency (F0-15). 2: Replace the fan and clean the air filter. 3: Contact the agent or ETAKE for technical support.

SN	Fault	Possible Causes	Solutions
6	The motor does not rotate after the AC drive runs.	<ol style="list-style-type: none"> <li>1: Check the motor and the motor cables.</li> <li>2: The AC drive parameters are set improperly (motor parameters).</li> <li>3: The cable between the drive board and the control board is in poor contact.</li> <li>4: The drive board is faulty.</li> </ol>	<ol style="list-style-type: none"> <li>1: Ensure the cable between the AC drive and the motor is normal.</li> <li>2: Replace the motor or clear mechanical faults.</li> <li>3: Check and re-set motor parameters.</li> </ol>
7	The DI terminals are disabled.	<ol style="list-style-type: none"> <li>1: The parameters are set incorrectly.</li> <li>2: The external signal is incorrect.</li> <li>3: The jumper bar across OP and +24 V becomes loose.</li> <li>4: The control board is faulty.</li> </ol>	<ol style="list-style-type: none"> <li>1: Check and reset the parameters in group F4.</li> <li>2: Re-connect the external signal cables.</li> <li>3: Re-confirm the jumper bar across OP and +24 V.</li> <li>4: Contact the agent or Inovance for technical support.</li> </ol>
8	The motor speed is always low in CLVC mode.	<ol style="list-style-type: none"> <li>1: The encoder is faulty.</li> <li>2: The encoder cable is connected incorrectly or in poor contact.</li> <li>3: The PG card is faulty.</li> <li>4: The drive board is faulty.</li> </ol>	<ol style="list-style-type: none"> <li>1: Replace the encoder and ensure the cabling is proper.</li> <li>2: Replace the PG card.</li> <li>3: Contact the agent or Inovance for technical support.</li> </ol>
9	The AC drive reports overcurrent and overvoltage frequently.	<ol style="list-style-type: none"> <li>1: The motor parameters are set improperly.</li> <li>2: The acceleration/deceleration time is improper.</li> <li>3: The load fluctuates.</li> </ol>	<ol style="list-style-type: none"> <li>1: Re-set motor parameters or re-perform the motor auto-tuning.</li> <li>2: Set proper acceleration/ deceleration time.</li> <li>3: Contact the agent or Inovance for technical support.</li> </ol>
10	Err17 is reported upon power-on or running.	The soft startup contactor is not picked up.	<ol style="list-style-type: none"> <li>1: Check whether the contactor cable is loose.</li> <li>2: Check whether the contactor is faulty.</li> <li>3: Check whether 24 V power supply of the contactor is faulty.</li> <li>4: Contact the agent or Inovance for technical support.</li> </ol>
11	<b>EEEE</b> is displayed upon power-on.	Related component on the control board is damaged.	Replace the control board.



## دفترچه راهنمای خلاصه فارسی اینورترهای ایتیک ETAKE

### پارامترهای اولیه راه اندازی اینورتر

پارامتر	نام پارامتر	مقدار پارامتر
1	حالت کنترل موتور	0: کنترل برداری بدون سنسور سرعت (در این حالت باید پارامترهای موتور شناسایی شود) 2: کنترل خطی (ولتاژ / فرکانس) پیش فرض از این حالت استفاده گردد
2	انتخاب منبع فرمان	0: فرمان از پنل 1: فرمان از ترمینال
3	منبع انتخاب فرکانس اصلی X	0: تنظیم دیجیتال ( غیر قابل قبول در هنگام قطع برق ) 1: تنظیم دیجیتال ( در صورت قطع برق آخرین مقدار ذخیره می شود ) 2: ورودی آنالوگ 0 تا 10 ولت 3: ولوم روی نمایشگر 6: چند مرجعی (MULTI STEP) 7: PLC 8: PID
4	فرکانس پیشفرض	0 تا حداکثر فرکانس (زمانی معتبر است که F0.03 روی 0 یا 1 تنظیم شده باشد)
5	حداکثر فرکانس	از 50 تا 1000 هرتز
6	فرکانس بیشینه بالا	فرکانس کمینه پایین (F0.14) تا فرکانس حداکثر فرکانس (F0.10)
7	فرکانس کمینه پایین	از 0 هرتز تا فرکانس بیشینه بالا (F0.12)
8	فرکانس کلید زنی	0.5 تا 16 کیلو هرتز
9	زمان شتاب	به ثانیه
10	زمان کاهش سرعت	به ثانیه

## پارامتر های ترمینال ورودی

مقدار پارامتر	نام پارامتر	پارامتر	
0: بدون عملکرد	انتخاب عملکرد DI 1	F4.00	1
1: راستگرد	انتخاب عملکرد DI 2	F4.01	2
2: چپ گرد	انتخاب عملکرد DI 3	F4.02	3
3: کنترل 3 سیمه (فرمان شاسی)	انتخاب عملکرد DI 4	F4.03	4
4: راستگرد سرعت دوم (JOG) که در F8.00 قابل تنظیم است	انتخاب عملکرد DI 5	F4.04	5
5: چپ گرد سرعت دوم (JOG) که در F8.00 قابل تنظیم است	انتخاب عملکرد DI 6	F4.05	6
12: ترمینال چند سرعتی، سرعت اول در پارامتر FC.01			
13: ترمینال چند سرعتی، سرعت دوم در پارامتر FC.02			
14: ترمینال چند سرعتی، سرعت سوم در پارامتر FC.04			
15: ترمینال چند سرعتی، سرعت چهارم در پارامتر FC.08			

## ترمینال خروجی

مقدار پارامتر	نام پارامتر	پارامتر	
0: بدون خروجی	رله خروجی 1 (T/A , T/B , T/C)	F5.02	1
1: اینورتر در حال کار	رله خروجی 2 (T/A , T/C)	F5.04	2
2: خروجی خطا (توقف)			
3: تشخیص سطح فرکانس خروجی FTD1 (F8.19 , F8.20)			
5: سرعت صفر هر تریز (در حالت توقف خروجی ندارد)			
6: هشدار اضافه بار موتور			

مقدار پارامتر	نام پارامتر	پارامتر	
01: بازگشت به تنظیمات کارخانه (به استثنای تنظیمات موتور)	بازگشت به تنظیمات پیشفرض	FP.01	1

### پارامترهای موتور

مقدار پارامتر	نام پارامتر	پارامتر	
0.1 تا 1000 کیلووات	توان نامی موتور	F1.01	1
1 تا 2000 ولت	ولتاژ نامی موتور	F1.02	2
0.01 تا 655.36 آمپر (قدرت درایو AC => 55 کیلووات) 0.1 تا 6553.5 آمپر (قدرت درایو AC < 55 کیلووات)	جریان نامی موتور	F1.03	3
0.01 تا حداکثر فرکانس	فرکانس نامی موتور	F1.04	4
1 تا 65535 دور بر دقیقه (RPM)	سرعت چرخش نامی موتور	F1.05	5

مقدار پارامتر	نام پارامتر	پارامتر	
0.1% تا 30%	گشتاور راه اندازی (Torque boost) برای کاربرد هایی که در فرکانس های پایین نیاز به گشتاور دارند. مقدار تنظیمی بیشتر از 9 توصیه نمی شود.	F3.01	1

## 1404/01/21 V2.0 ETAKE دستورالعمل راه اندازی اینورتر پمپهای خورشیدی

**روش 1 (حالت پیشفرض):** برای راه اندازی اینورتر نیاز به هیچ تنظیمی وجود ندارد و می بایست: برق ورودی پنل هارا با رعایت "مثبت و منفی" به ورودی دستگاه متصل کنید. همچنین موتور را به خروجی های "U-V-W" متصل کنید.

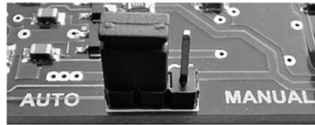
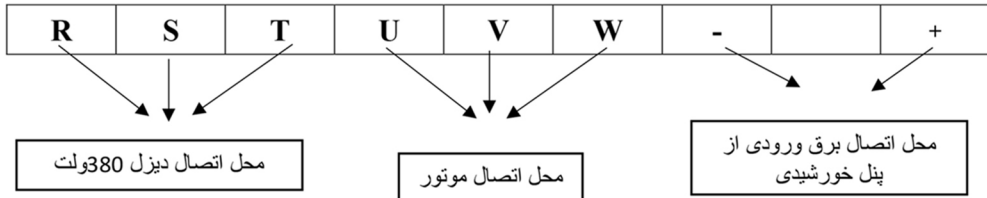

\*جامپر روی برد کنترل\*

**روش 2:** چنانچه روش پیشفرض عملکرد مناسبی نداشت میتوانید از روش دوم کنترلی به این صورت استفاده کنید:

جامپر را روی برد کنترل را به شرح عکس زیر قرار دهید و پارامتر های زیر را وارد کنید.

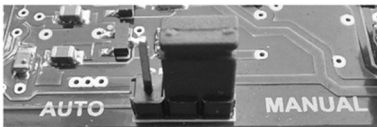

\*جامپر روی برد کنترل\*

ردیف	پارامترها
1	FP.01=1
2	F0.01=2
3	F0.03=8
4	F3.01=0
5	FA.03=1
6	FA.05=100.0
7	FA.06=10.0
8	FA.08=0
9	A5.06=40
10	F0.02=1
11	به روش زیر = FA.01

به منظور تنظیم این روش کنترلی نیاز است که ولتاژ سری شده پنل ها روی مقدار نامی آن تنظیم شود.

مثال: چنانچه 13 عدد پنل سری شده داریم ولتاژ برابر است با:

$$42V * 13 = 546V$$

42 ولت ولتاژ Vmp (ولتاژ زیر بار پنل) میباشد.

FA.01 باید به نحوی تنظیم شود که ولتاژ سری شده پنل ها زیر بار نزدیک 546 V باشد حال چنانچه ولتاژ کمتر بود، FA.01 را بیشتر مکنیم. چنانچه ولتاژ بیشتر بود FA.01 را کمتر می کنیم، تا به ولتاژ مورد نظر برسد.

## Wiring

Recommended Braking Resistor

Voltage class		220VAC				380/400/415VAC				
Drive Model		2.2kW 2R2-23A	4kw -3R7-23A	5.5kw -5R5-23A	7.5kw -7R5-23A	4kw 3R743A	5.5kw 5R543A	7.5kw 7R543A	11kw 01143A	15kw 01543A
Braking Resistor	Recommended Power, [W]	500	750	1200	1500	750	1200	1500	2500	3000
	Recommended Resistance, [ $\Omega$ ]	$\geq 65$	$\geq 45$	$\geq 22$	$\geq 16$	$\geq 130$	$\geq 90$	$\geq 65$	$\geq 43$	$\geq 32$

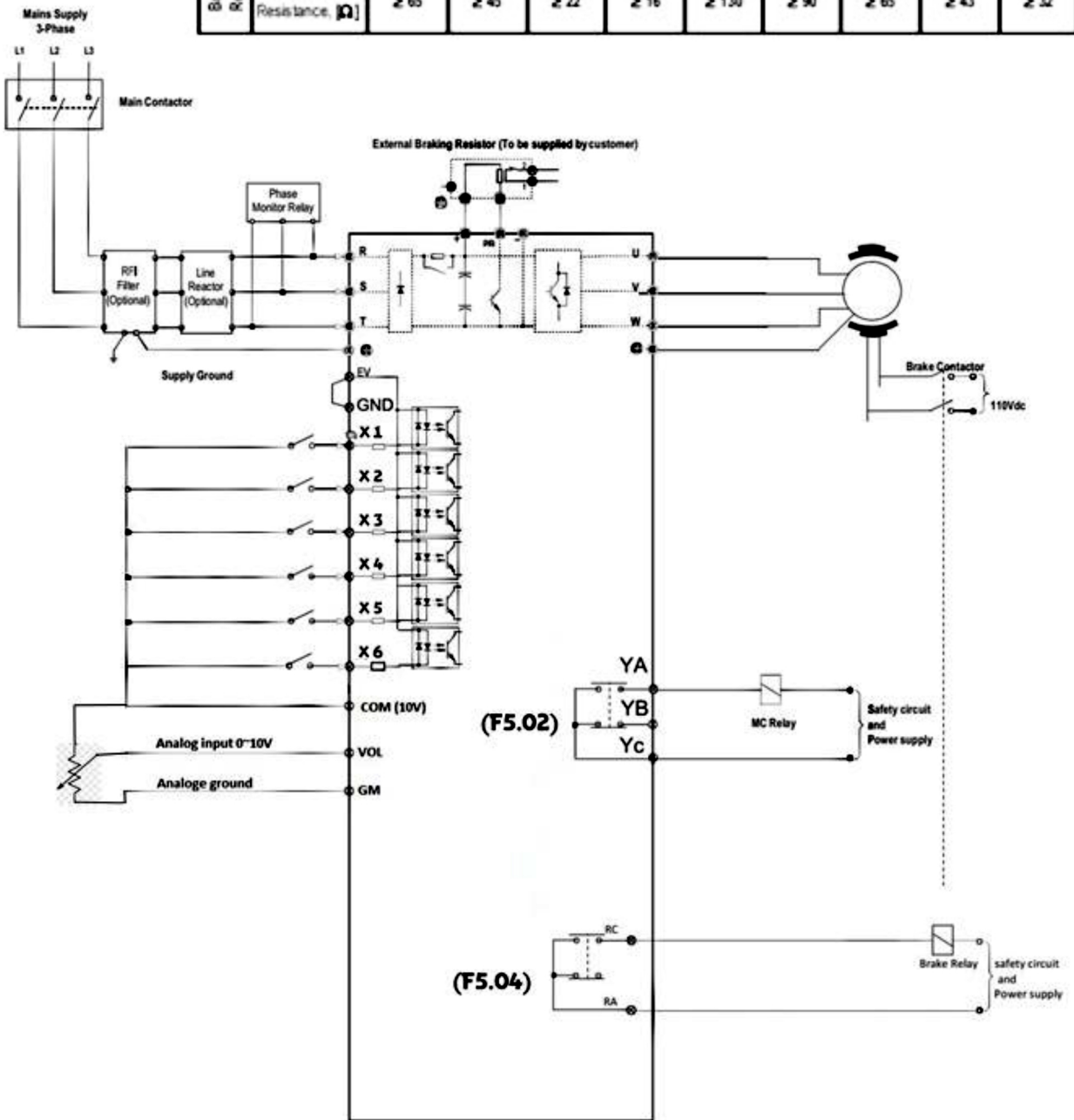



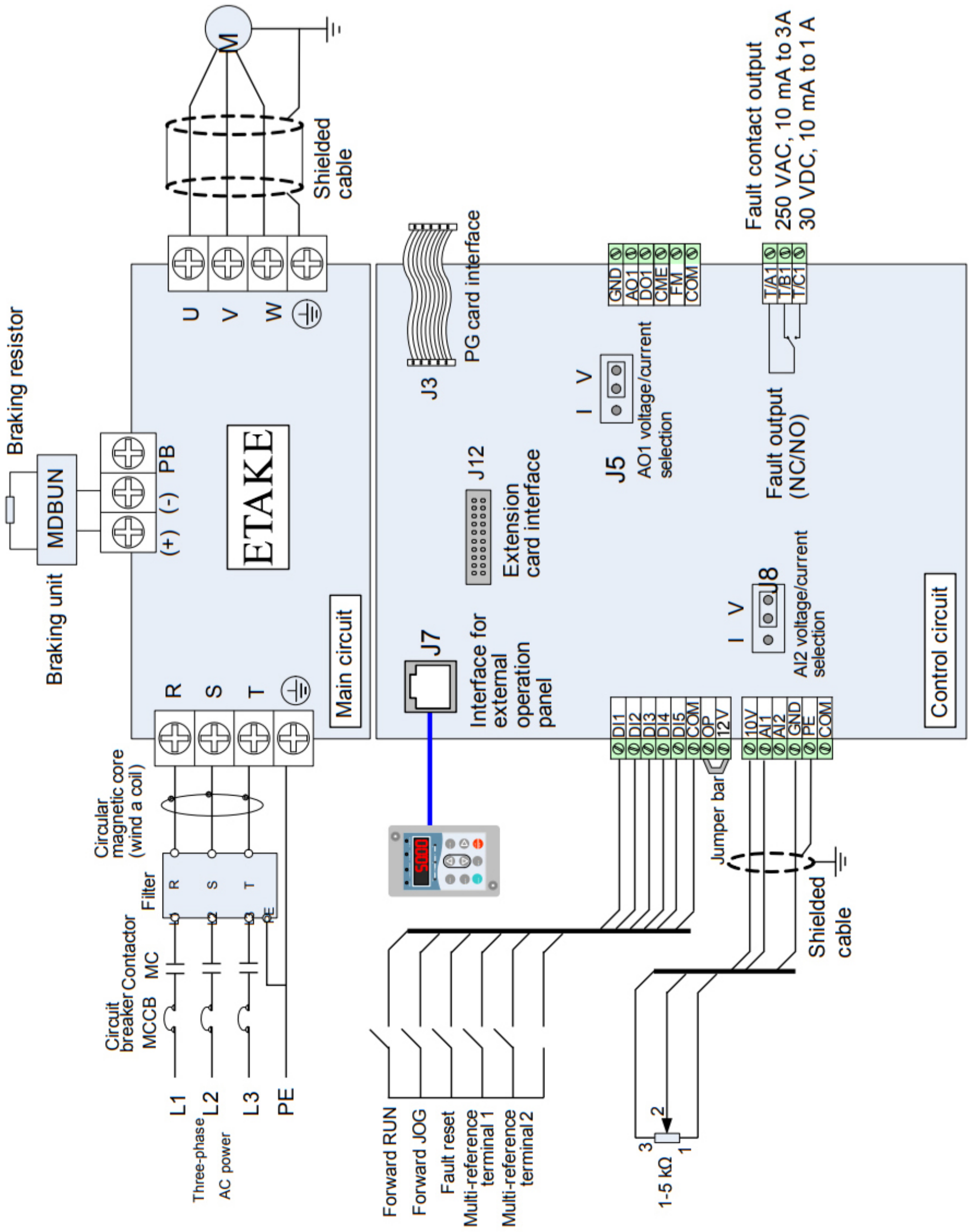



## شرایط گارانتی دستگاه اینورتر :

- ✓ در هنگام نصب و استفاده از اینورتر نکات زیر را رعایت فرمایید:
- ✓ نیاز است برق فیوز DC در برق ورودی گذاشته شود.
- ✓ کلیه سیم های متصل به اینورتر، سرسیم داشته باشد.
- ✓ کلیه ترمینال ها محکم شده باشد.
- ✓ از یک تابلو برق مناسب جهت نصب اینورتر استفاده شود تا از هر گونه صدمه فیزیکی، گرد و خاک، آلودگی و رطوبت زیاد محافظت شود.
- ✓ نوسانات برق که به دستگاه آسیب برساند شامل گارانتی نمی شود.
- ✓ در صورت ایجاد خسارت از کارکرد اینورتر فقط تعمیر اینورتر
- ✓ (در صورت داشتن گارانتی) به عهده مجموعه می باشد.

**[www.etakeco.com](http://www.etakeco.com)**